

Specifications for EMH Style DLVM-125 Single Girder Under Running End Trucks 5.125 In. Diameter Wheels

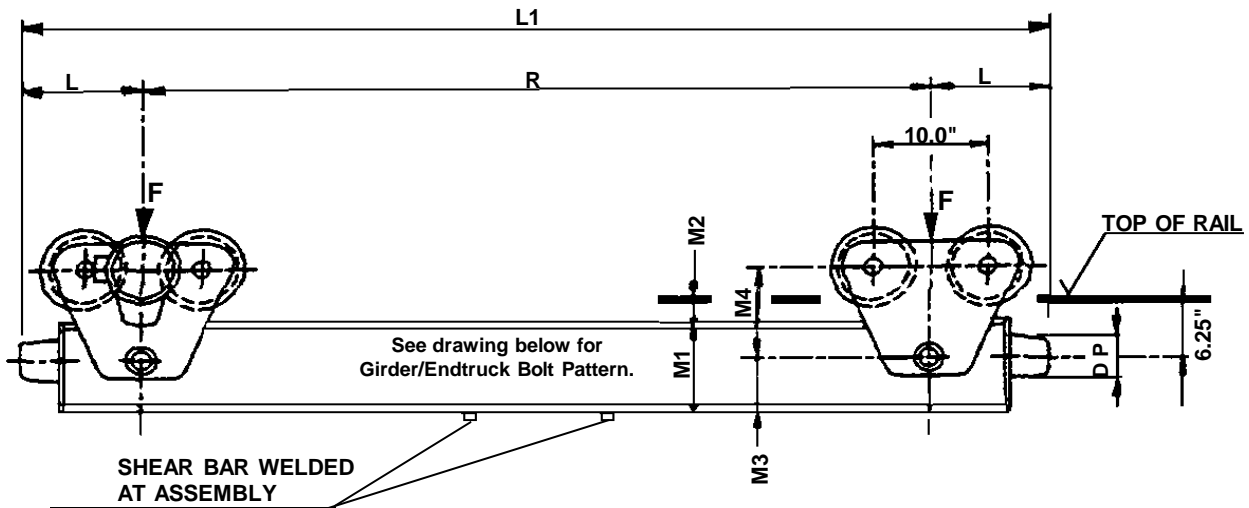

Girder/Endtruck Bolt Pattern

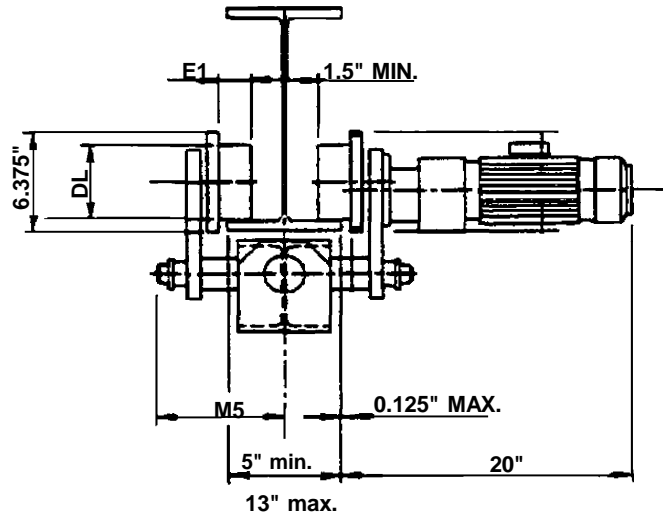
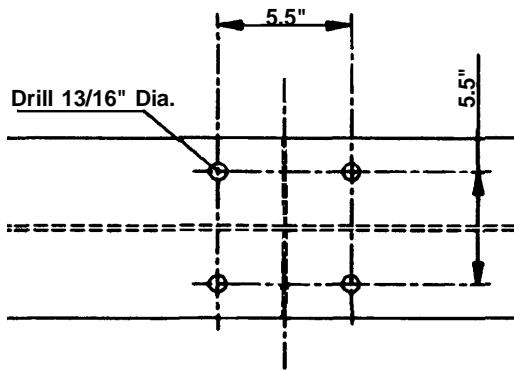

Consult EMH for wider flange or
patented track.

Model No.	Wheel Base (R) Ft.-In.	Corner Load Lbs. (F)	Movable Mass Lbs.	Endtruck Load Max. Lbs.	120 fpm Motor HP	Max Span Ft.	Wt. Lbs.	L In.	L1 Ft.-In.	DL In.	DP In.	E1 In.	M1 In.	M2 In.	M3 In.	M4 In.	M5 In.
D-125.250.1500.1	5-0	9,800	23,000	19,600	0.75	39	660	9	6-6	5	3	1	8.25	1.75	5	7.5	13
D-125.250.2000.1	6-6	9,800	23,000	19,600	0.75	52	760	9	8-0	5	3	1	8.25	1.75	5	7.5	13
D-125.250.2300.1	7-6	9,800	23,000	19,600	0.75	64	825	9	9-0	5	3	1	8.25	1.75	5	7.5	13