

Specifications for EMH Style EDL-100 Close Headroom Single Girder Under Running End Trucks 4 In. Diameter Wheels

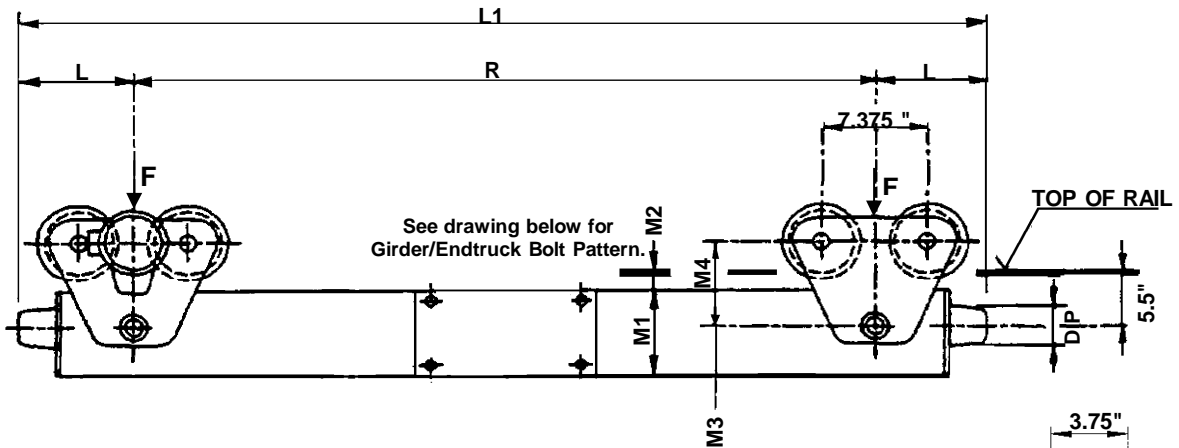

Girder/Endtruck Bolt Pattern

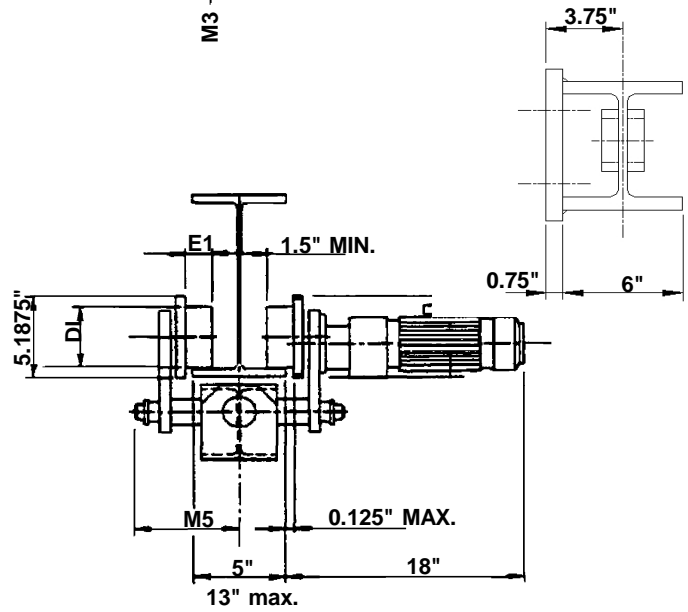
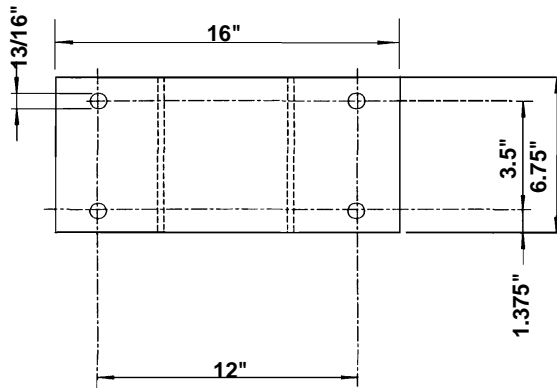

Consult EMH for wider flange
or patented track.

Model No.	Wheel Base (R) Ft.-In.	Corner Load Lbs.	Movable Mass Lbs.	Endtruck Load F Max. Lbs.	120 fpm Motor HP	Max Span Ft.	Wt. Lbs.	L In.	L1 Ft.-In.	DL In.	DP In.	E1 In.	M1 In.	M2 In.	M3 In.	M4 In.	M5 In.
E-100.210.1500.1	5-0	4,800	12,000	9,600	0.33	39	350	7.5	6-3	4	3	0.875	6.5	1.75	4	6.5	12
E-100.210.2000.1	6-6	4,800	12,000	9,600	0.33	52	390	7.5	7-9	4	3	0.875	6.5	1.75	4	6.5	12
E-100.210.2300.1	7-6	4,800	12,000	9,600	0.33	64	460	7.5	8-9	4	3	0.875	6.5	1.75	4	6.5	12