

Specifications for EMH Style EDL-125 Close Headroom Single Girder Under Running End Trucks 5 In. Diameter Wheels

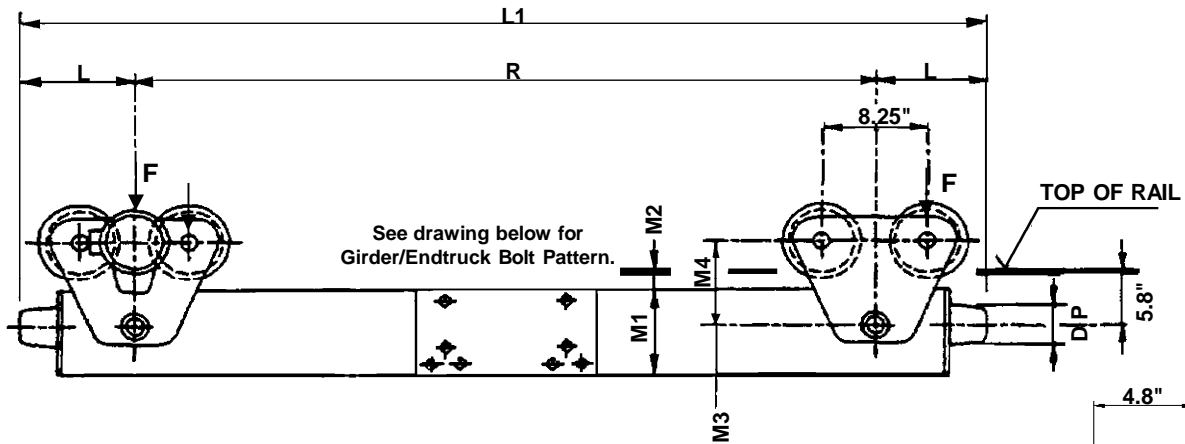

Girder/Endtruck Bolt Pattern

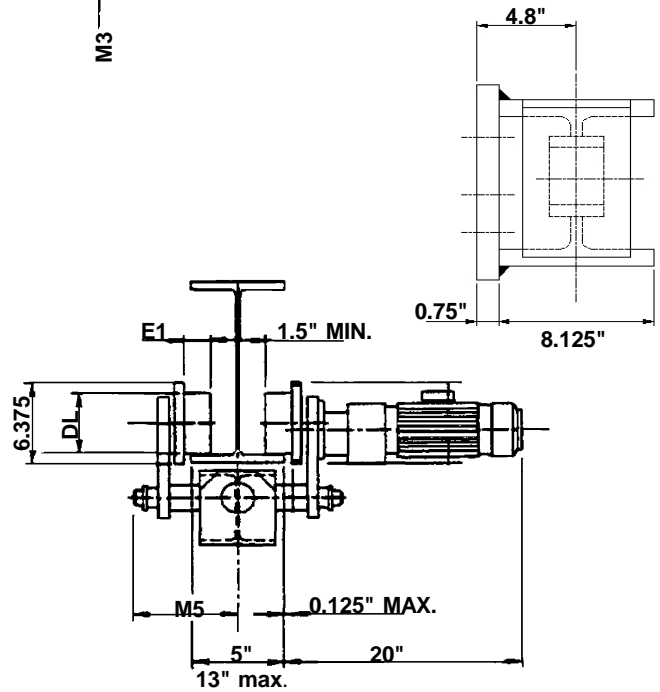
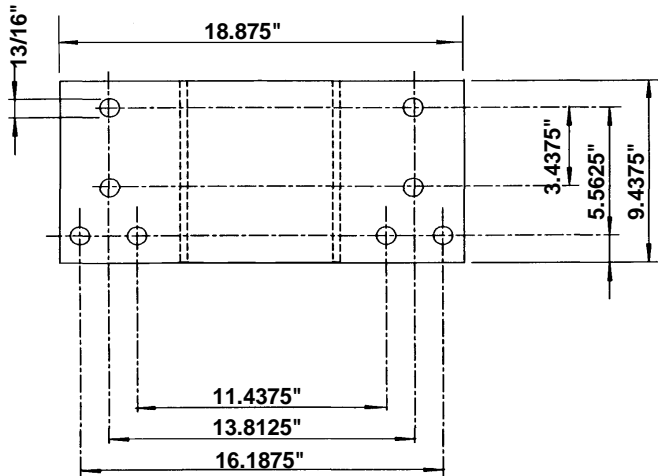

Consult EMH for wider flange
or patented track.

Model No.	Wheel Base (R) Ft.-In.	Corner Load Lbs.	Movable Mass Lbs.	Endtruck Load F Max. Lbs.	120 fpm Motor HP	Max Span Ft.	Wt. Lbs.	L In.	L1 Ft.-In.	DL In.	DP In.	E1 In.	M1 In.	M2 In.	M3 In.	M4 In.	M5 In.
E-125.250.2000.1	6-6	9,800	23,000	19,600	0.75	52	760	9	8-0	5.125	3	1	8.25	1.75	5	7.5	13
E-125.250.2300.1	7-6	9,800	23,000	19,600	0.75	64	825	9	9-0	5.125	3	1	8.25	1.75	5	7.5	13