

## Specifications for EMH Style UHB-315 Top Running Bogie End Trucks 12 In. Diameter Wheels

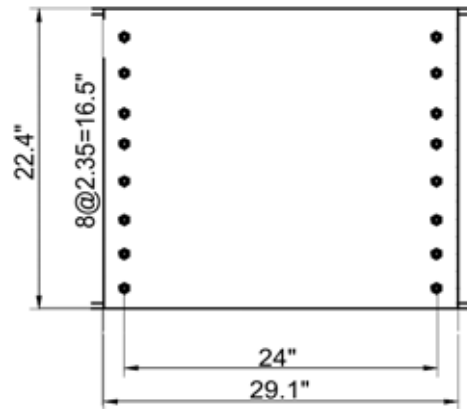

Endtruck/Girder  
Connection Plate

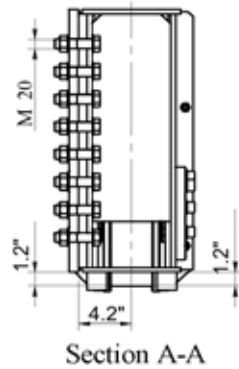
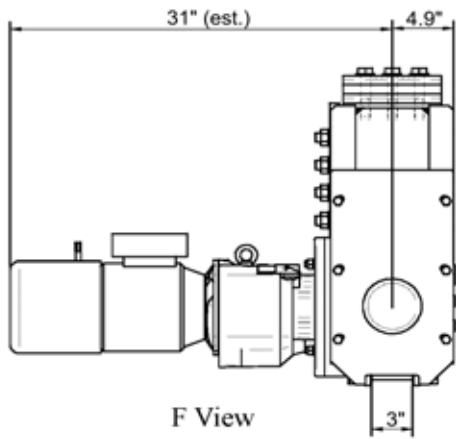
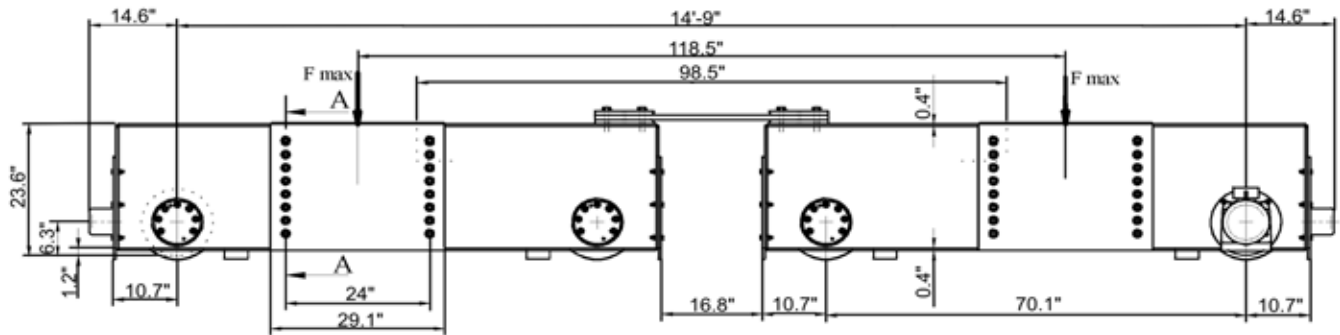

Model No.	No. of Drives	F Load Lbs.	120 fpm Motor HP	Wt. per Pr. Lbs.
UHB-315.575.4200.1.25.73.2	2	76,430	2 x 7.5	5,300