

EMH Wire Rope Hoists

Dimensions and Specifications

Hoist Model: EH8100 HF
Trolley Type: Top Running for Double Girder Cranes

Reeving: 4 to 2

Capacity: 10 tons

Rope Diameter:	0.43"	11 mm
Drum Diameter:	10.67"	271 mm
Hoist Motor HP:	20 HP	
Trolley Motor HP:	2x 0.75 HP	
Lifting Speed:	25 FPM VFD	
Trolley Speed:	80 FPM VFD	

Duty Service Classification	
HMI	H4
FEM	2m
CMAA	D
ISO	M5

Dimensions (inch)				
Refer to drawing below. Rail width E is for ref.	H1		C	15.0
	H2	29	B	6.45
	K	45	M1	21.1
	T	=SP*0.5	M2	21.1
	O	19	R	42.1
	F	2.63	DL	155 mm
	E (max)	2.0	DA	130 mm
			P	3.15
		G	3.31	

Standard SP (trolley gauge):			
	20 ft	30 ft	50 ft
(May vary with lift)	63"	63"	63"
Weight lbs (est.)	3440	3640	3860

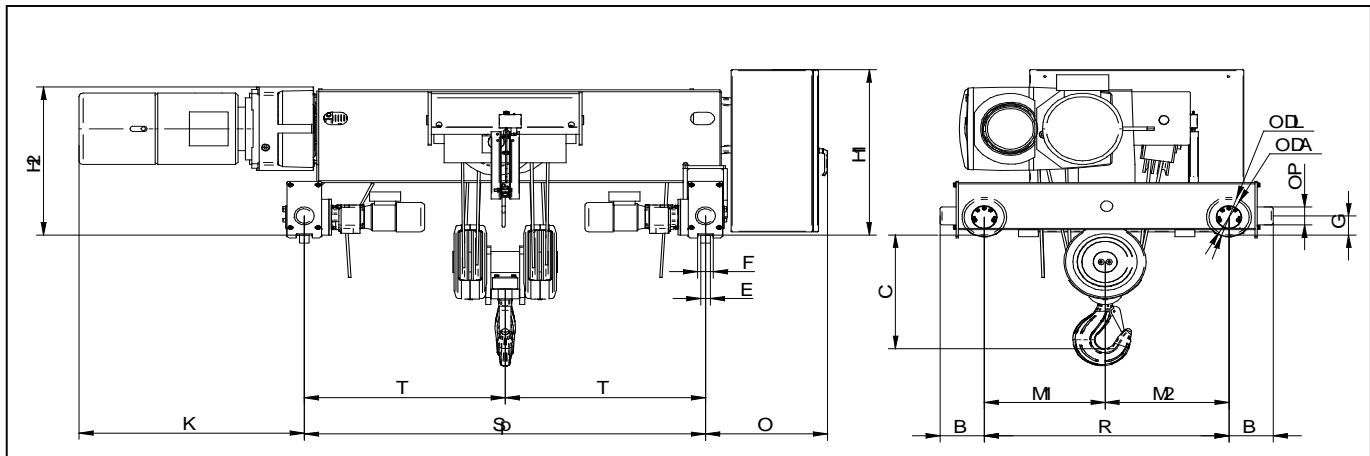

E·M·H[®]
Engineered Material Handling