

# EMH Wire Rope Hoists

## Dimensions and Specifications

**Hoist Model: EH8600 HF**  
**Trolley Type: Top Running for Double Girder Cranes**

**Reeving: 12 to 2**

**Capacity: 60 tons**

|                          |            |        |
|--------------------------|------------|--------|
| <b>Rope Diameter:</b>    | 0.63"      | 15 mm  |
| <b>Drum Diameter:</b>    | 16"        | 406 mm |
| <b>Hoist Motor HP:</b>   | 60 HP      |        |
| <b>Trolley Motor HP:</b> | 2x 2.0 HP  |        |
| <b>Lifting Speed:</b>    | 14 FPM VFD |        |
| <b>Trolley Speed:</b>    | 60 FPM VFD |        |

| Duty Service Classification |    |
|-----------------------------|----|
| <b>HMI</b>                  | H4 |
| <b>FEM</b>                  | 2m |
| <b>CMAA</b>                 | D  |
| <b>ISO</b>                  | M5 |

| Dimensions (inch)                                |                |          |           |        |
|--|----------------|----------|-----------|--------|
| Refer to drawing below. Rail width E is for ref. | <b>H1</b>      | ---      | <b>C</b>  | 43.0   |
|  | <b>H2</b>      | 43       | <b>B</b>  | 11.90  |
|  | <b>K</b>       | 47       | <b>M1</b> | 32.5   |
|  | <b>T</b>       | =SP*0.5  | <b>M2</b> | 32.5   |
|  | <b>O</b>       | 26       | <b>R</b>  | 65.0   |
|  | <b>F</b>       | 3.26     | <b>DL</b> | 340 mm |
|  | <b>E (max)</b> | 2.6      | <b>DA</b> | 315 mm |
|  |                |          | <b>P</b>  | 4.72   |
|  |                | <b>G</b> | 5.67      |        |

| Standard SP (trolley gauge): |       |        |         |
|------------------------------|-------|--------|---------|
|                              | 30 ft | 50 ft  | 70 ft   |
| <b>(May vary with lift)</b>  | 98.5" | 157.5" | 177.25" |
| <b>Weight lbs (est.)</b>     | 12600 | 13300  | 14000   |

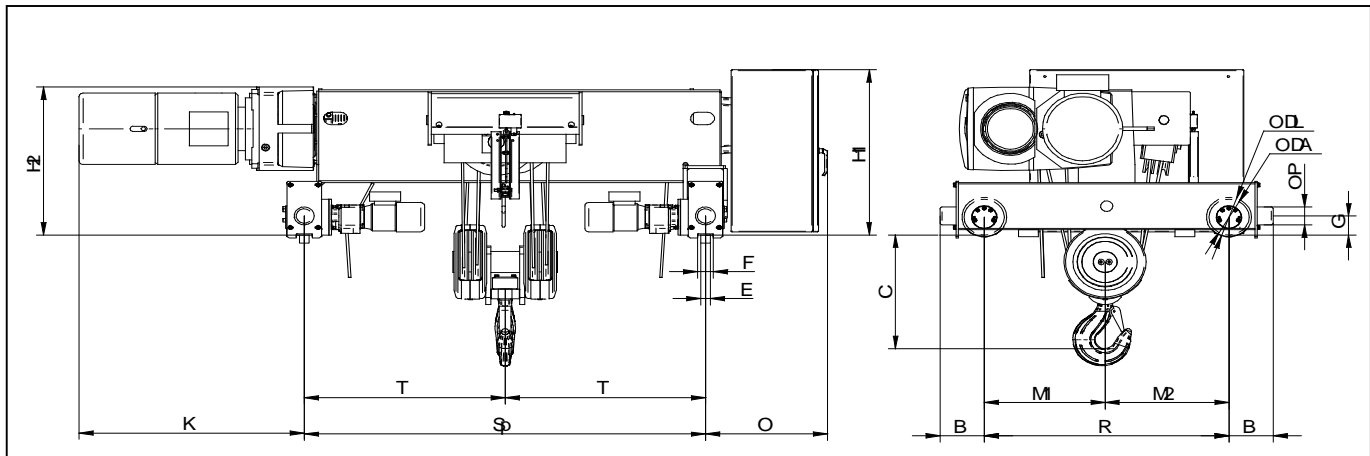

**E·M·H<sup>®</sup>**  
**Engineered Material Handling**