

EMH Wire Rope Hoists

Dimensions and Specifications

Hoist Model: EM 1000D
Trolley Type: Top Running for Double Girder Cranes

Reeving: 8 to 2

Capacities: 5 tons

| | |
|----------------------------------|----------|
| Rope Diameter: | 2x6.4 mm |
| Drum Diameter: | 6.75" |
| Sheave Diameter: | 6.25" |
| Hoist Motor HP: | 7.2/1.2 |
| Trolley Motor HP: | 2 x 0.5 |
| Speeds (fpm): | 16/2.6 |
| Std. Trolley Speed (fpm): | 80 VFD |

| | | | |
|------------------------------------|----------|------------|------------|
| Duty Service Classification | | FEM | HMI |
| Capacity in US Tons | 5 | 1 | H3 |

| | | |
|---|-------------|-------|
| Dimensions (inches): | | |
| Refer to drawing below. M, T and Standard SP (trolley gauge) dimensions plus weight shown in adjacent tables. | B: | 28 |
| | C: | 8 |
| | DA: | 5.125 |
| | DL: | 6.125 |
| | E: | 2.5 |
| | F: | 2.25 |
| | G: | 4 |
| | H: | 21.25 |
| | K: | 3.875 |
| | O *: | 16.5 |
| | P: | 3.125 |
| | R: | 42 |
| | U *: | --- |
| X: | --- | |

| | | | | |
|-------------------------------------|--------------|---------------|---------------|---------------|
| Standard SP (trolley gauge): | | | | |
| Varies with lifts shown at right. | 7 ft. | 16 ft. | 27 ft. | 33 ft. |
| | | | | |
| | 63 | 78.75 | 98.5 | 98.5 |

| | | | | |
|--------------------------------|-----------|----------------|----------------|-------------------|
| Available Lifts (feet): | | | | |
| M, T, and Wt. vary with lift. | | M (in.) | T (in.) | Wt. (lbs.) |
| | 7 | 0 | 28.5 | 1020 |
| | 16 | 0 | 33.625 | 1070 |
| | 27 | 0 | 38.5 | 1170 |
| | 33 | 0 | 42.5 | 1280 |

* Dimensions O and U may vary depending on the type of control.

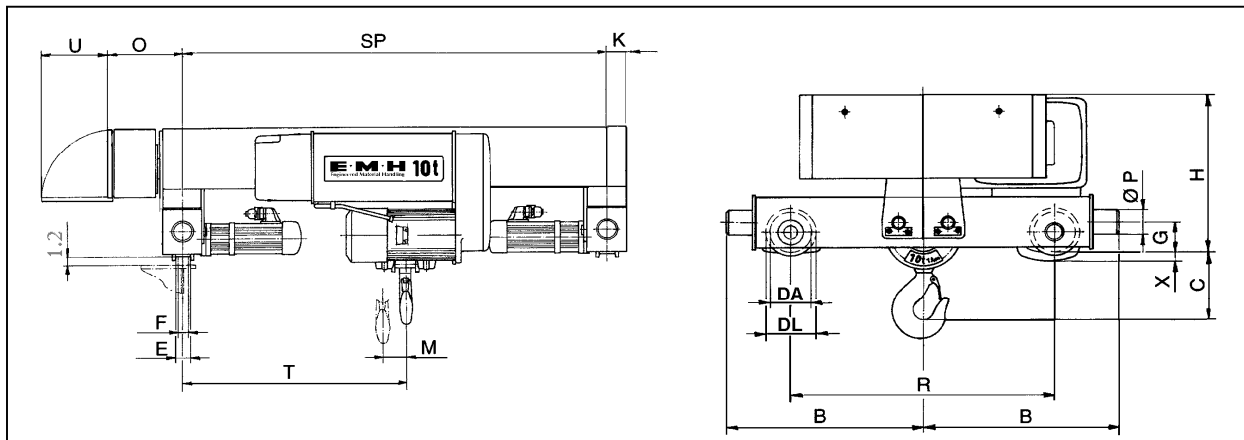

E·M·H[®]
 Engineered Material Handling