

# EMH Wire Rope Hoists

## Dimensions and Specifications

Hoist Model: EM 6000Z

Trolley Type: Top Running for Double Girder Cranes

Reeving: 8 to 2

Capacities: 30, 35, 40 and 50 tons

Rope Diameter:	2x16 mm
Drum Diameter:	12.75
Sheave Diameter:	12.875"
Hoist Motor HP:	2x24.2/3.9
Trolley Motor HP:	2 x 1.5
Speeds (fpm):	14/2.3
Std. Trolley Speed (fpm):	80 VFD

Duty Service Classification		FEM	HMI
Capacity in US Tons	30	3	H4
	35	3	H4
	40	2	H4
	50	1	H3

Dimensions (inches):		
Refer to drawing below. T and Standard SP (trolley gauge) dimensions plus weight shown in adjacent tables.	B:	40.875
	C:	25.625
	DA:	12.375
	DL:	13.375
	E:	2.75
	F:	2.5
	G:	5
	H:	42.5
	K:	4.5
	O*:	17.75
	P:	3.125
R:	54	

Standard SP (trolley gauge):			
Varies with lifts shown at right.	20 ft.	33 ft.	50 ft.
	63	78.75	98.5

Available Lifts (feet):			
T and Wt. vary with lift.		T (in.)	Wt. (lbs.)
	20	31.5	6800
	33	39.375	7200
	50	49.25	8000

\* Dimensions O and U may vary depending on the type of control.

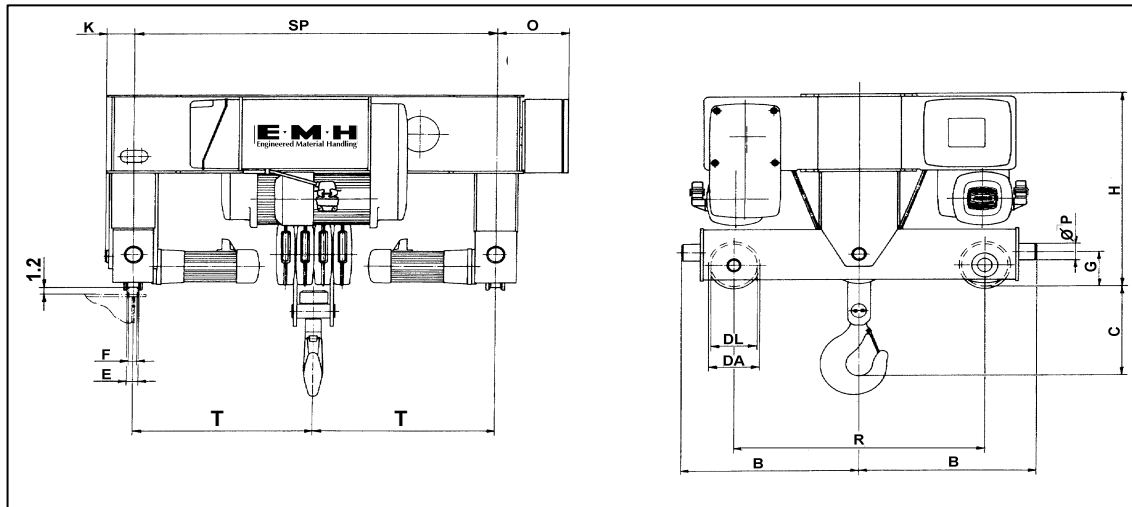

**EMH**  
Engineered Material Handling