

EMH Wire Rope Hoists Dimensions and Specifications

Hoist Model: EM 800D
Trolley Type: Top Running for Double Girder Cranes

Reeving: 4 to 1

Capacities: 2 and 3 tons

Rope Diameter:	6.4 mm
Drum Diameter:	5.625"
Sheave Diameter:	5.75"
Hoist Motor HP:	4.1/0.68
Trolley Motor HP:	2 x 0.5
Speeds (fpm):	16/2.6, 20/3.2, 25/4.1
Std. Trolley Speed (fpm):	80 VFD

Duty Service Classification	FEM	HMI
Capacity in US Tons		
2	2	H4
3	2	H4

Dimensions (inches):		
Refer to drawing below. M, T and Standard SP (trolley gauge) dimensions plus weight shown in adjacent tables.	B:	27.5
	C:	8
	DA:	4
	DL:	5
	E:	2.75
	F:	2.25
	G:	3.375
	H:	20
	K:	4.25
	O*:	16.5
	P:	3.25
	R:	42.125
	U*:	---
X:	---	

Standard SP (trolley gauge):			
Varies with lifts shown at right.	20 ft.	33 ft.	50 ft.
	63	78.75	98.5

Available Lifts (feet):				
M, T, and Wt. vary with lift.		M (in.)	T (in.)	Wt. (lbs.)
	20	3.75	33.5	902
	33	6.375	42.5	990
	50	9.375	54	1078

* Dimensions O and U may vary depending on the type of control.

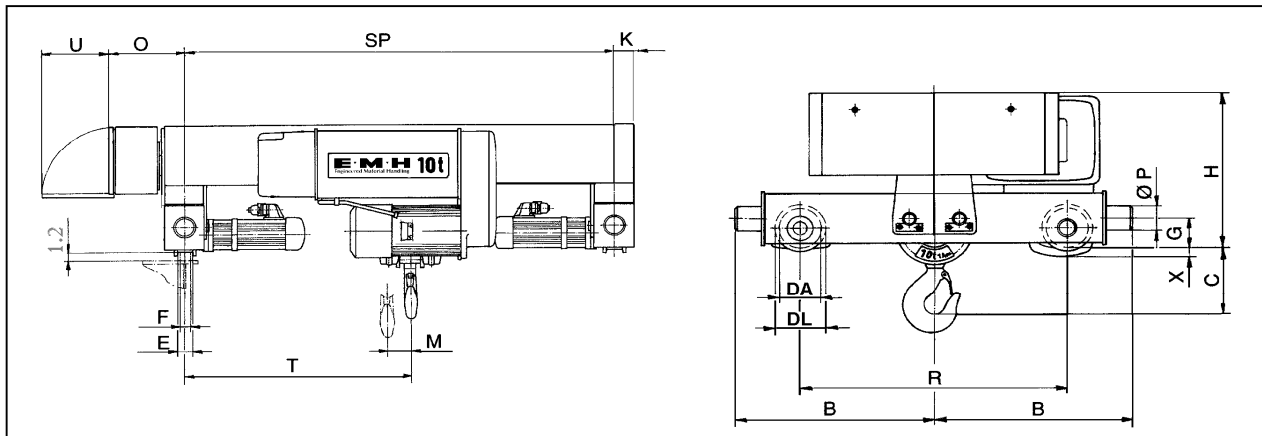

E·M·H[®]
Engineered Material Handling