

Specifications for EMH Style HS-315 Top Running Double Girder End Trucks 12 In. Diameter Wheels

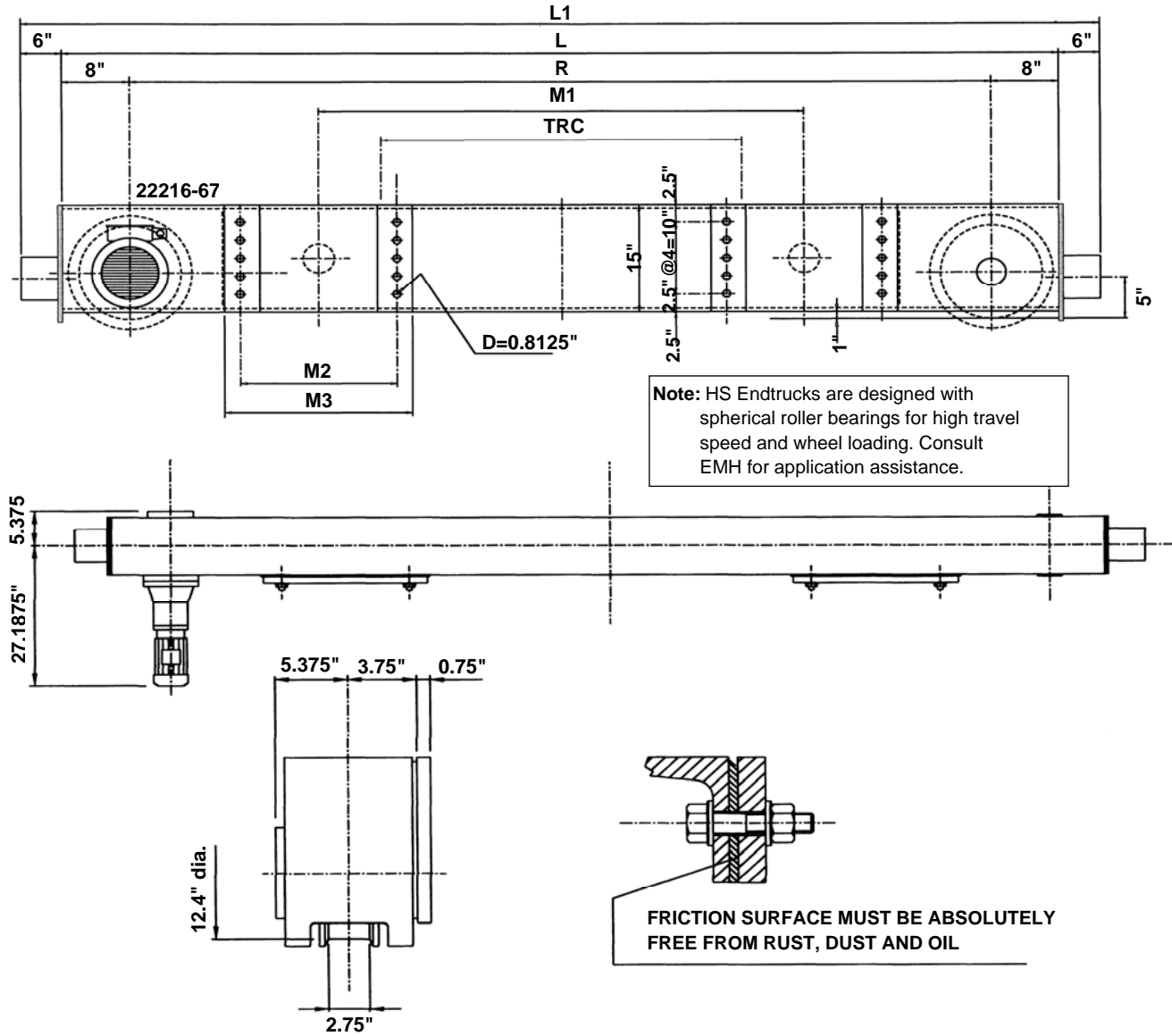

Model No.	Wheel Load	Moving Mass Lbs. 200 fpm VFD	Wheel Base (R) Ft.-In.	200 fpm Motor HP	L Ft.-In.	L1 Ft.-In.	M1 In.	M2 In.	M3 In.	TRC In.	Weight per Pair
HS-315.405.2700.3.16	38,850	91,520	8-10	2 x 4.0	10-2	11-2	71	12	16	63	3,200
HS-315.405.2900.4.16	38,850	91,520	9-6	2 x 4.0	10-10	11-10	75	16	20	63	3,340
HS-315.405.3200.5.16	38,850	91,520	10-6	2 x 4.0	11-10	12-10	79	20	24	63	3,540
HS-315.405.3800.5.20	38,850	91,520	12-6	2 x 4.0	13-10	14-10	94.75	20	24	78.75	3,950
HS-315.405.4600.6.25	38,850	91,520	15-0	2 x 4.0	16-4	17-4	118.5	24	28	98.5	4,460