

Specifications for EMH Style HSE100 Top Running Single Girder Endtrucks 4in. Diameter Wheels

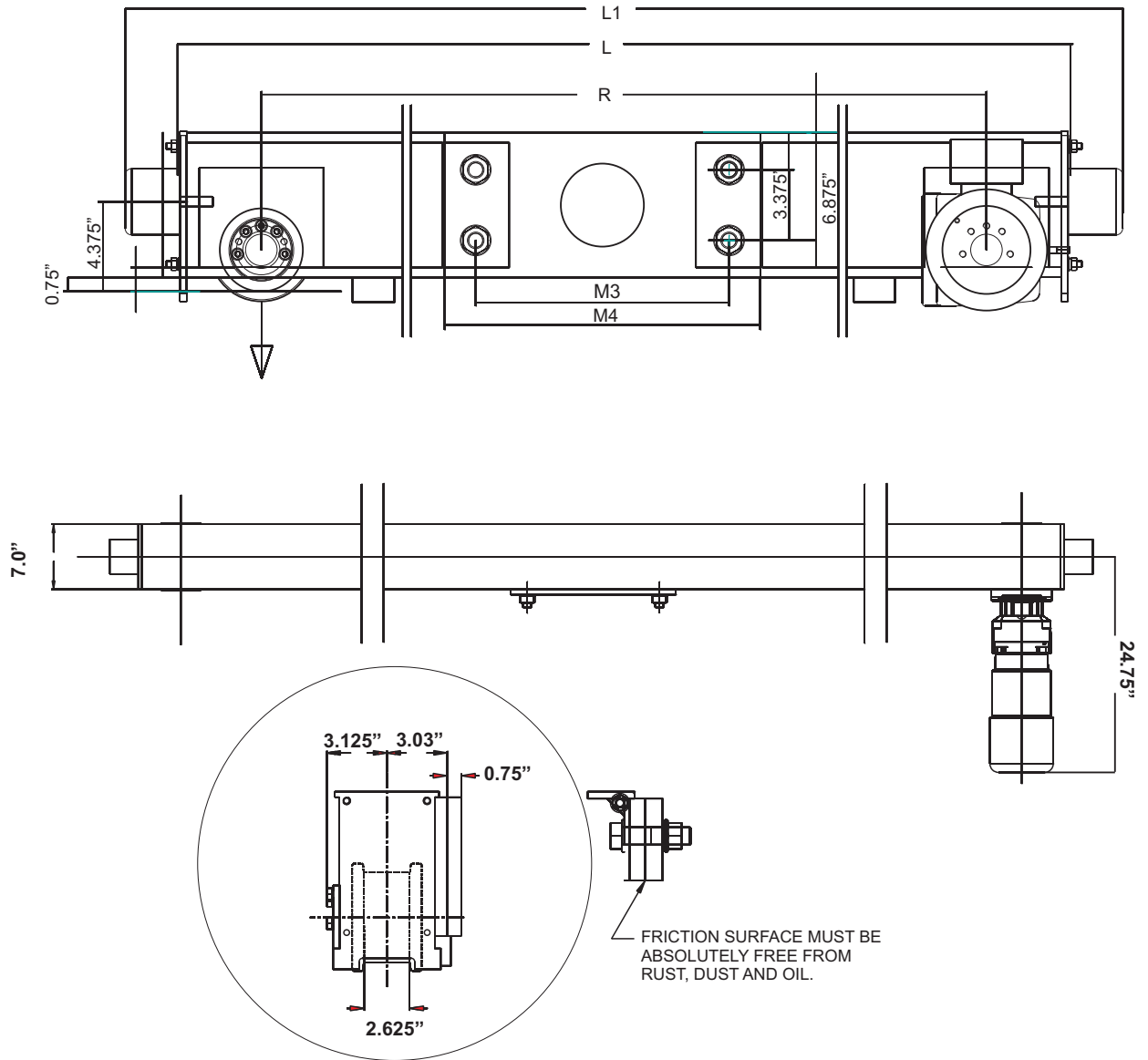

Model No.	Wheel Load	Moving Mass Lbs.	120 fpm Motor HP	Wheel Base (R) Ft.-In.	L Ft.-In.	L1 Ft.-In.	M3 In.	M4 In.	Weight per Pair
HSE-100.174.900	7,190	24,000	2 x 0.75	3-0	3-7	4-1	12	15	492
HSE-100.174.1500	7,190	24,000	2 x 0.75	5-0	5-7	6-1	12	15	472
HSE-100.174.1900	7,190	24,000	2 x 0.75	6-3	6-10	7-4	12	15	572
HSE-100.174.2200	7,190	24,000	2 x 0.75	7-3	7-10	8-4	12	15	662
HSE-100.174.2700	6,700	24,000	2 x 0.75	8-10	9-5	9-11	12	15	812