

Specifications for EMH Style UHB-400 Top Running Bogie End Trucks 16 In. Diameter Wheels

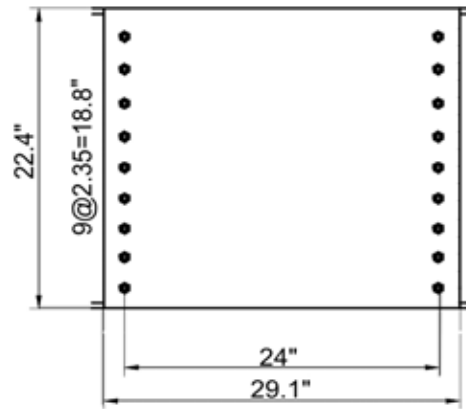

Endtruck/Girder Connection
Plate

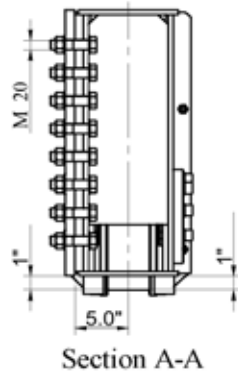
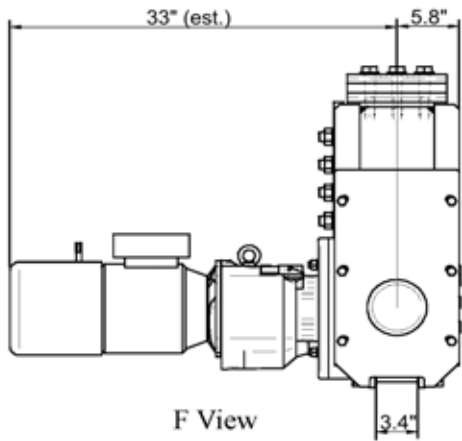
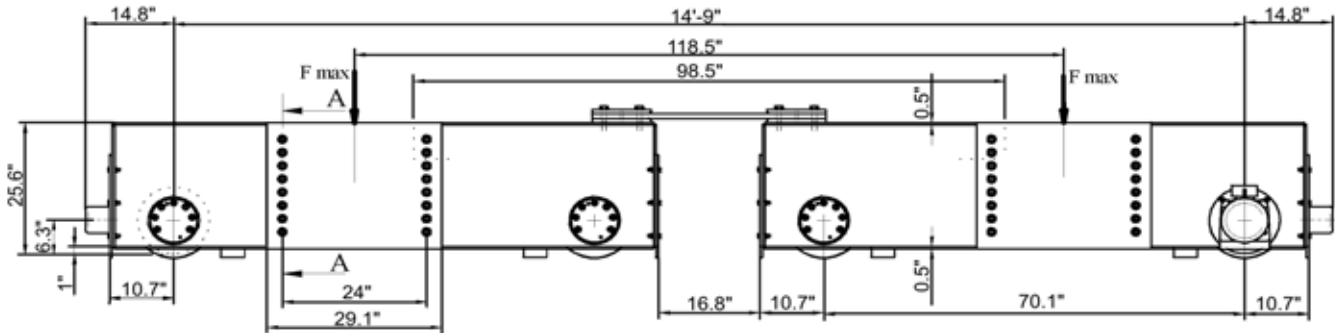
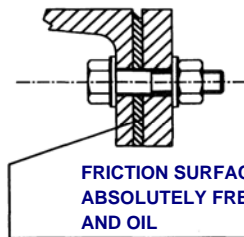

FRICION SURFACE MUST BE
ABSOLUTELY FREE FROM RUST, DUST
AND OIL

Model No.	No. of Drives	F Load Lbs.	120 fpm Motor HP	Wt. per Pr. Lbs.
UHB-400.650.4500.1.25.83.2	2	92,170	2 x 7.5	7,500