

# Specifications for EMH Style UHB-500 Top Running Bogie End Trucks 20 In. Diameter Wheels

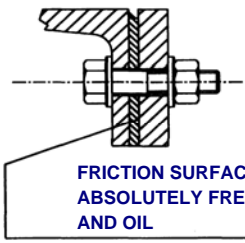
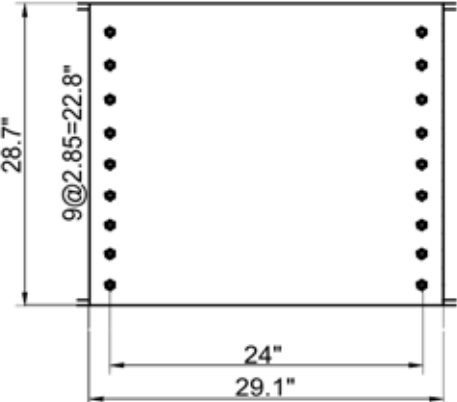
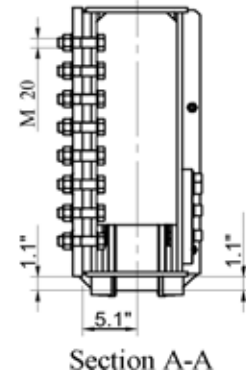
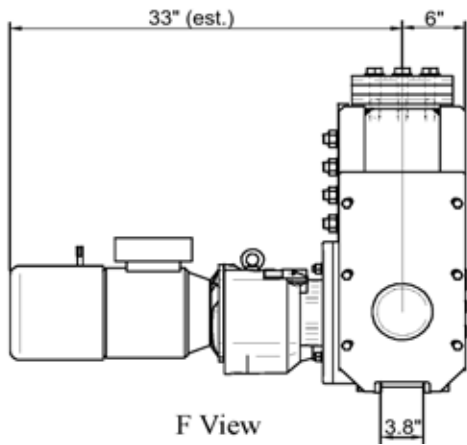
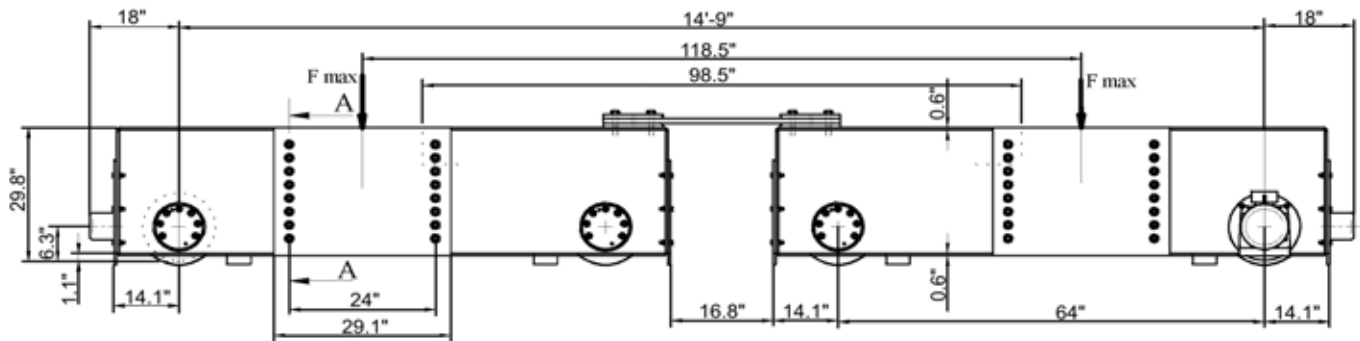

Model No.	No. of Drives	F Load Lbs.	120 fpm Motor HP	Wt. per Pr. Lbs.
UHB-500.750.4500.1.25.63.2	2	137,130	2 x 10	10,500