

# Specifications for EMH Style UHB-630 Top Running Bogie End Trucks 25 In. Diameter Wheels

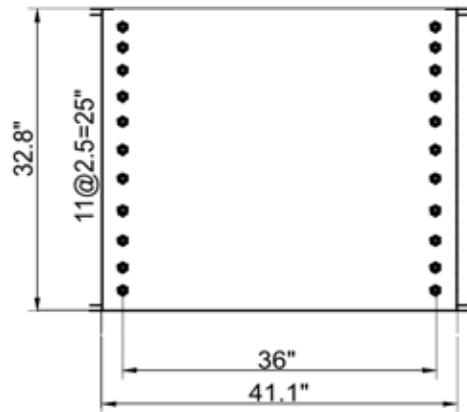

Endtruck/Girder Connection  
Plate

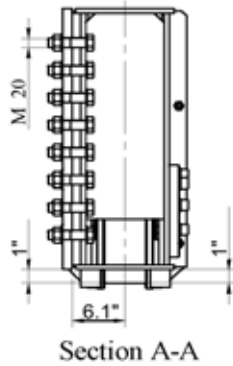
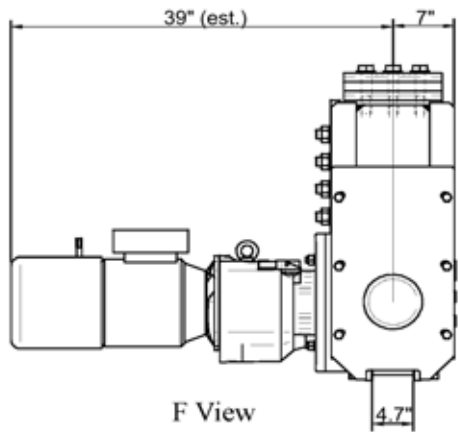
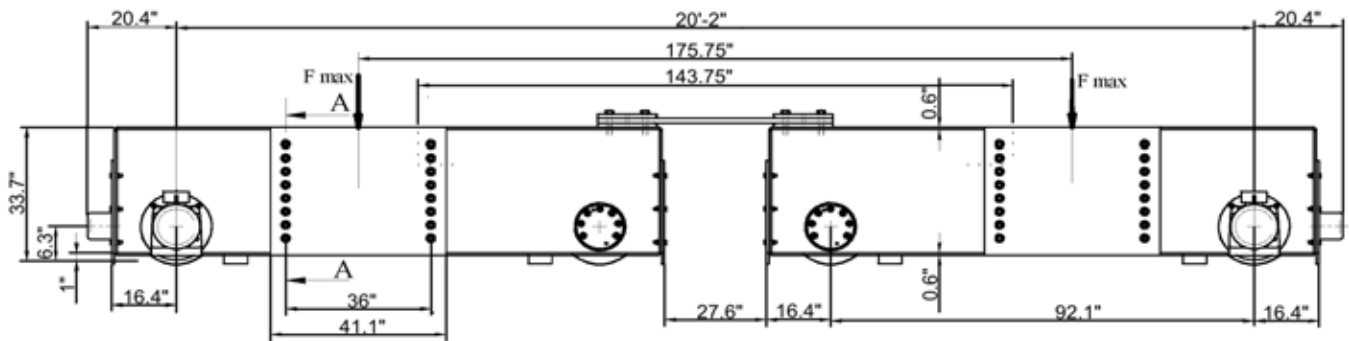
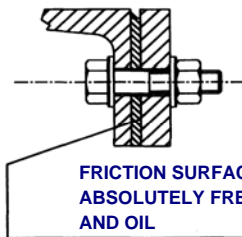

FRICION SURFACE MUST BE  
ABSOLUTELY FREE FROM RUST, DUST  
AND OIL

Model No.	No. of Drives	F Load Lbs.	120 fpm Motor HP	Wt. per Pr. Lbs.
UHB-630.900.6150.1.35.83.4	4	222,550	4 x 7.5	18,000