

EMH Wire Rope Hoists

Dimensions and Specifications

Hoist Model: EH8050 HF
Trolley Type: Top Running for Double Girder Cranes

Reeving: 4 to 2

Capacity: 5 tons

Rope Diameter:	0.31"	8 mm
Drum Diameter:	6.73"	171 mm
Hoist Motor HP:	10 HP	
Trolley Motor HP:	2x 0.5 HP	
Lifting Speed:	25 FPM VFD	
Trolley Speed:	80 FPM VFD	

Duty Service Classification	
HMI	H4
FEM	2m
CMAA	D
ISO	M5

Dimensions (inch)				
Refer to drawing below. Rail width E is for ref.	H1		C	12
	H2	22	B	6.45
	K	29	M1	21.06
	T	=SP*0.5	M2	21.06
	O*	15	R	42.125
	F	2.63	DL	124 mm
	E (max)	2.0	DA	100 mm
			P	3.15
		G	3.25	

Standard SP (trolley gauge):			
	20 ft	30 ft	50 ft
(May vary with lift)	63"	63"	63"
Weight lbs	1570	1770	2000

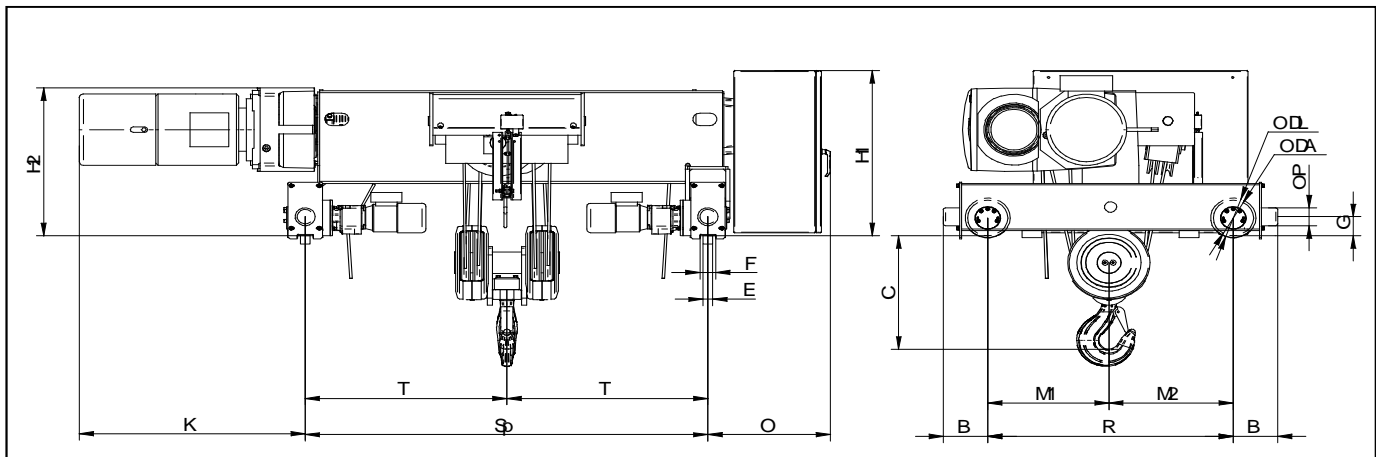

E·M·H[®]
 Engineered Material Handling