

EMH Wire Rope Hoists

Dimensions and Specifications

Hoist Model: EH8150 HF
Trolley Type: Top Running for Double Girder Cranes

Reeving: 8 to 2

Capacity: 15 tons

Rope Diameter:	0.39"	10 mm
Drum Diameter:	10.67"	271 mm
Hoist Motor HP:	25 HP	
Trolley Motor HP:	2x 1.0 HP	
Lifting Speed:	20 FPM VFD	
Trolley Speed:	80 FPM VFD	

Duty Service Classification	
HMI	H4
FEM	2m
CMAA	D
ISO	M5

Dimensions (inch)				
Refer to drawing below. Rail width E is for ref.	H1	---	C	18.5
	H2	29	B	7.30
	K	43	M1	24.0
	T	=SP*0.5	M2	24.0
	O	24	R	48.0
	F	3	DL	185
	E (max)	2.3	DA	160
			P	3.15
		G	4.14	

Standard SP (trolley gauge):			
	20 ft	30 ft	50 ft
(May vary with lift)	63"	78.75	98.8
Weight lbs (est.)	3310	3750	4200

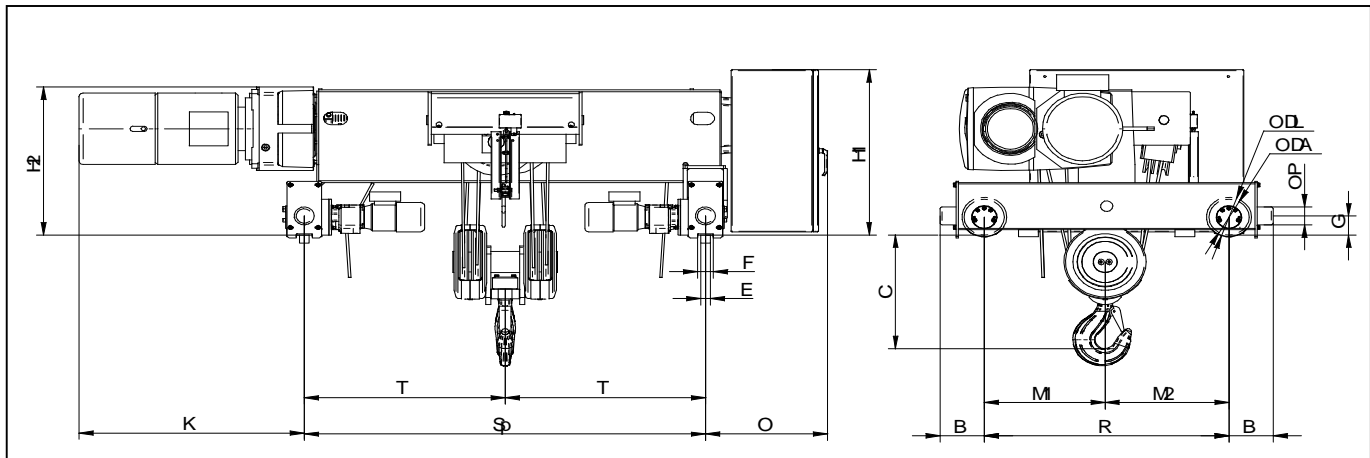

E·M·H[®]
 Engineered Material Handling