

EMH Wire Rope Hoists

Dimensions and Specifications

Hoist Model: EH8300 HF
Trolley Type: Top Running for Double Girder Cranes

Reeving: 8 to 2

Capacity: 30 tons

Rope Diameter:	0.51"	13 mm
Drum Diameter:	12.8"	325 mm
Hoist Motor HP:	40 HP	
Trolley Motor HP:	2x 2.0 HP	
Lifting Speed:	16 FPM VFD	
Trolley Speed:	80 FPM VFD	

Duty Service Classification	
HMI	H4
FEM	2m
CMAA	D
ISO	M5

Dimensions (inch)				
Refer to drawing below. Rail width E is for ref.	H1	---	C	24.0
	H2	41	B	10.40
	K	47	M1	24.0
	T	=SP*0.5	M2	24.0
	O	26	R	48.0
	F	3	DL	284 mm
	E (max)	2.3	DA	250 mm
			P	4.72
		G	5.51	

Standard SP (trolley gauge):			
	20 ft	30 ft	50 ft
(May vary with lift)	78.75"	98.5"	98.5"
Weight lbs (est.)	6070	6620	7170

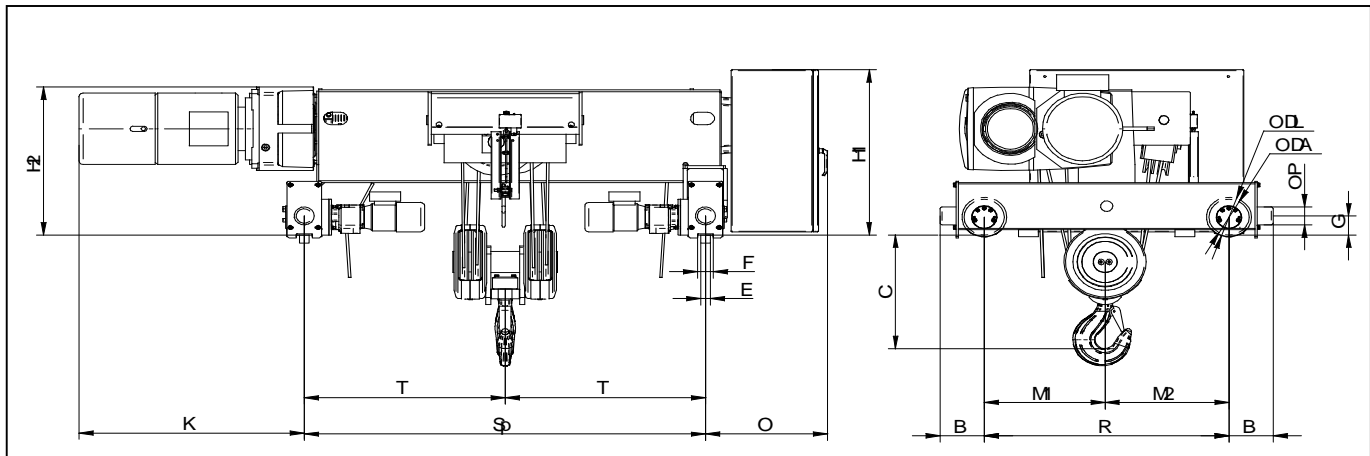

E·M·H[®]
Engineered Material Handling