

EMH Wire Rope Hoists

Dimensions and Specifications

Hoist Model: EM 1000SU
Trolley Type: Monorail for Single Girder Cranes

Reeving: 2 to 1

Capacities: 2 tons

Rope Diameter:	8 mm
Drum Diameter:	6.75"
Sheave Diameter:	6.25"
Hoist Motor HP:	5.7/1.0
Trolley Motor HP:	2 x 0.33
Trolley Wheel Diameter:	4"
Speeds (fpm):	33/5, 41/6.2, 50/6.2
Trolley Speed:	65 VFD

Duty Service Classification	FEM	HMI
Capacity in US Tons	2	H4

Dimensions (inches):		
Refer to drawing below. L, M and R dimensions shown in adjacent tables.	A:	19
	B:	20.5
	C:	40
	H:	6.5
	N-Min:	3.25
	N-Max:	8
	R1:	7.375

Available Lifts (feet):				
	L (in.)	M (in.)	R (in.)	Wt. (lbs.)
40	24	8.25	44	1520
65	31	13.75	60	1600
100	40	20.75	76	1820

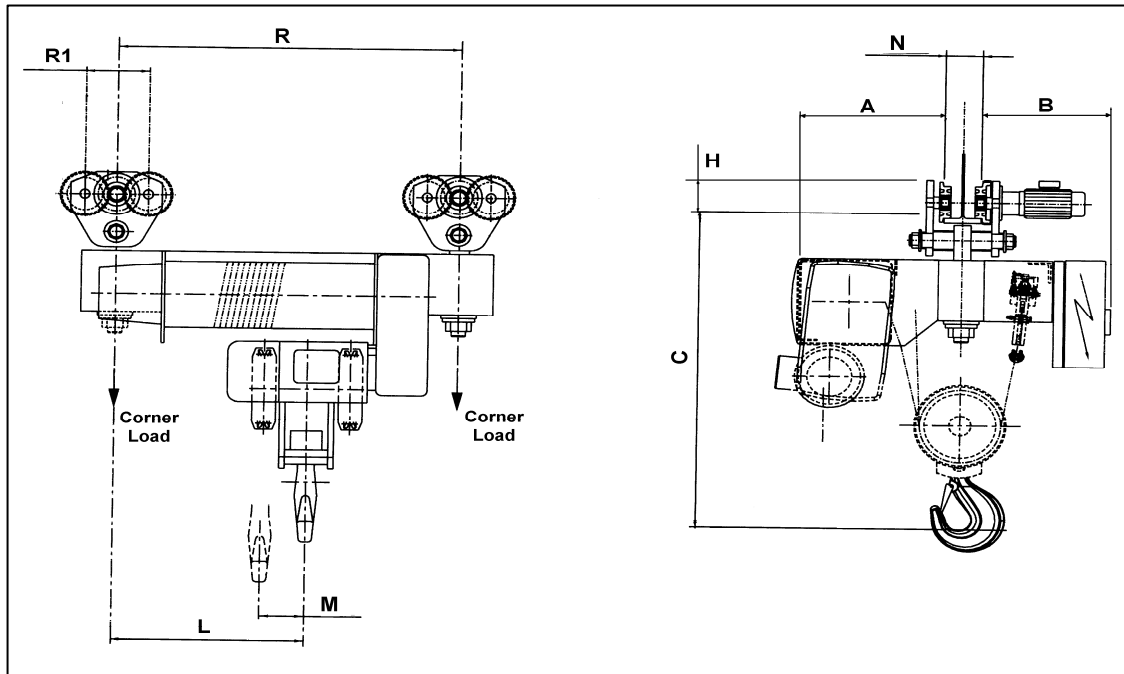

E·M·H
Engineered Material Handling