

# EMH Wire Rope Hoists

## Dimensions and Specifications

Hoist Model: EM 800SU  
Trolley Type: Monorail for Single Girder Cranes

Reeving: 4 to 1

Capacities: 2 and 3 tons

Rope Diameter:	6.4 mm
Drum Diameter:	5.625"
Sheave Diameter:	5.75"
Hoist Motor HP:	4.0/0.59
Trolley Motor HP:	2x0.33
Trolley Wheel Diameter:	4"
Speeds (fpm):	16/2.6, 20/3.2, 25/4.2
Trolley Speed:	65 VFD

Duty Service Classification	FEM	HMI
Capacity in US Tons		
2	3	H4
3	2	H4

Dimensions (inches):		
Refer to drawing below. L, M and R dimensions shown in adjacent tables.	A:	16.75
	B:	17.875
	C:	40
	H:	3
	N-Min:	3.25
	N-Max:	8
	R1:	7.375

Available Lifts (feet):				
	L (in.)	M (in.)	R (in.)	Wt. (lbs.)
20	24	4.375	44	1450
33	31	7.25	60	1530
50	40	10.875	76	1750

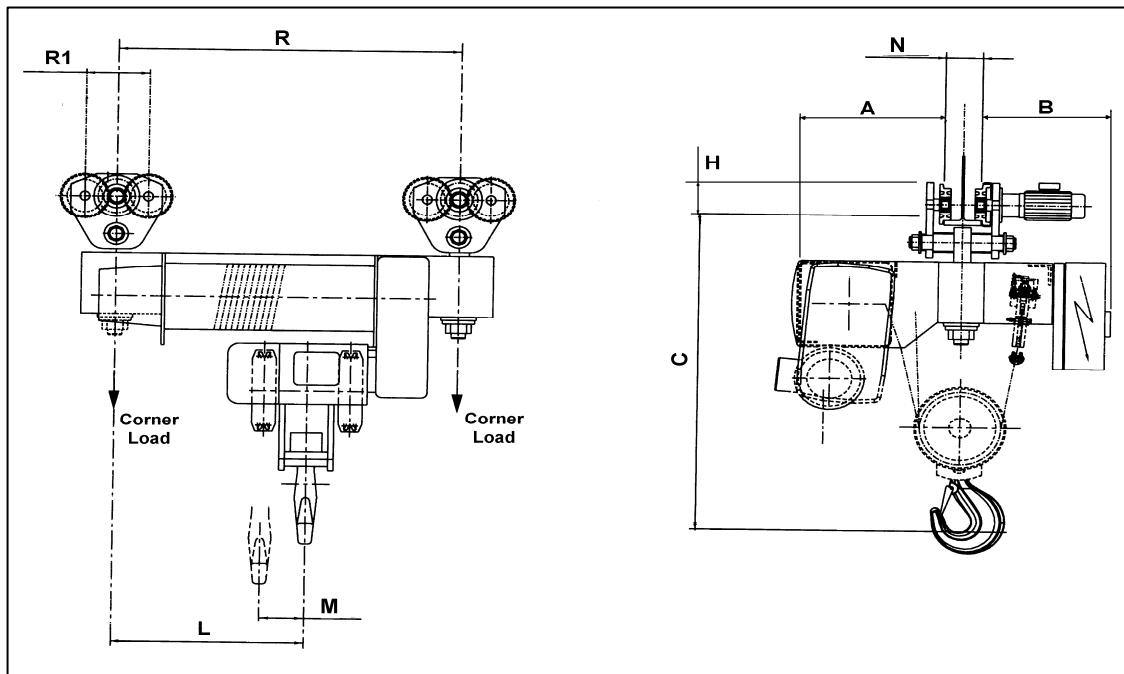

**E·M·H**  
Engineered Material Handling