



Safety
Components
Installation & Startup
Service, Maintenance & Operation

Contents	Page
Safety - - - - -	- - - 3
Rail and Components - - - - -	- 9-20
Air and Electrification - - - - -	21-24
Accessories - - - - -	- - 26
Installation - - - - -	27-32
Installation Protocol - - - - -	33-34

**The information in this manual is accurate to the best of our knowledge.
Revisions may be made as they become necessary.**

1. General Information

1.1 General Notes on Hazards and Notification

You must notify EMH in writing about any questions within thirty days of installation. Reading this manual is absolutely necessary to every safe operation of the equipment. EMH will presume you have read this entire manual unless you notify EMH in writing that you do not understand any part of this manual. When the product is in operation, there are hazardous exposed live wire components and hazardous rotating or moving parts inside the product, any of which can be dangerous.

Contact with water, concentrated acids or caustic solutions may result in damage to plastic components or the corrosion of metal parts; any parts affected by such damage or corrosion must be replaced as soon as possible.

Severe personal injury to people or damage to property may occur as a result of:

- the forbidden removal of safety covers for electrical or mechanical parts
- improper use of the equipment in any other way except in the way it was intended to be used
- overriding or ignoring any safety feature
- inadequate or poor repair, use or maintenance
- operation without proper training
- the use of shortcuts or to override or substitute any part or portion of the equipment

Failure to comply with the safety instructions given in this manual can lead to injury, or death. Every feature of this equipment is designed with your safety in mind.

The product can present hazards to life and limb, if it is operated in any other way than for the purpose for which it is intended or used by untrained or inadequately trained personnel. "Intended purpose" means only and solely the purpose for which the equipment was specified and ordered, and for no other use

The operator of the product must ensure that operation and maintenance personnel are instructed sufficiently before starting work with or on the product.

Because of the risk of injury due to clothes or parts of the body catching on or being drawn into the equipment, personnel working with the product must not wear any loose clothing, unprotected long hair or jewelry. Rings must not be worn when working with any electrical portion of this product.

Persons under the influence of alcohol, drugs, or medicines impairing their reactions must not perform any work on, or with, or to the product.

The product must not be operated in hazardous environments except where the product has been specifically ordered and designed for such use. The intended use must be specified and submitted in writing to EMH as part of the order. All uses and all intended uses can be derived or understood from written communication only.

During operation: Compliance with all the precautions required by this Manual before, during, and after commissioning and all the general safety requirements, especially those concerning operational safety and accident prevention, is essential. Failure to comply with these precautions and requirements may lead to personal injury or death.

The use of unapproved or unsuitable tools or auxiliary equipment can result in injury. Only proper tools intended for use on the equipment are permitted.

In connection with the movement of components, squeeze and shear points can occur with the equipment and between the equipment and its surroundings. You must therefore always keep a safe distance from moving or rotating components to prevent parts of the body, clothing, or your hair or any other object from being caught in the equipment.

Extreme caution must be used so that none of the following situations happen in close proximity to the equipment: Extreme heat, sparking (e.g., during welding), water, the use of detergents or open flames in the vicinity of components, which are combustible or may be affected, deformed or changed by heat (e.g., wood, plastics, oil, grease, electrical systems or wiring) must be avoided. Otherwise, there may be a serious risk of fire and consequently may result in the development of toxic fumes, damage to insulation, or parts of the equipment. The dangers of fire and consequences of it are obvious but the nature and danger of the toxic fumes are unknown, so these problems must be avoided as they can result in serious harm or damage to property or injury to people.

1.2 Uses for the Intended Purpose

The system described in this document is designed for the carrying and lifting of loads, subject to the maximum load capacity and the load groups for which it has been specified. Load capacity, and load groups are indicated in the data sheet or test book of each product. For safety, efficacy and general life of the equipment, these regulations must be followed explicitly.

Among other things, equipment is not considered to be used for the specific intended purpose if:

- the maximum permissible load capacity is exceeded; or,
- loads are pulled diagonally; or,
- loads are torn away, dragged or pulled; or,
- the equipment is used to catch falling loads; or,
- the equipment is used to lift persons with or without loads; or,
- the equipment is used for an inching or jogging operation; or,
- reversing the operation of the equipment (operation in the opposite direction, when the system is in motion); or for an,

- intentional operation against emergency end stops; and,
- colliding against other objects.

AT NO TIME IS THE EQUIPMENT TO BE USED TO CARRY PEOPLE IN ANY WAY.

(See also Section 2.2 “Safety Instructions for the User”).

1.3 About Warranty Information

This portion of the manual does not change, alter or modify EMH's actual warranty. For specific warranty information, please review EMH's warranty. The EMH warranty must be referred to in every or any warranty claim or for any other information regarding EMH's warranty. There is no substitute for examining and following EMH's original warranty accompanying the purchase of this equipment. The information presented here are only general ideas. Again, only reference to the actual warranty expresses the “legal” warranty.

EMH will assume absolutely no liability for any damage to the crane or hoist resulting from abnormal operation, work performed improperly or misused by anyone authorized or not, or for claims by third parties.

Caution! If you modify any components, assemble components other than in accordance with the installation instructions and/or plans or use any components other than genuine EMH components, you do it solely under your own responsibility and EMH will be released from any warranty obligations for the entire equipment.

For the safe and reliable operation of the product and for the retention of warranty rights, it is essential to use genuine EMH parts when you need spare parts. Using genuine EMH parts are insufficient unless the repairs are done by trained, qualified and authorized personnel. Safe operation is only possible within the service life stated if the crane/hoist is operated within its rating and the installation, operation, and maintenance instructions are followed.

You will find the hoist class and load group of your crane/hoist on the data sheet or in the manual for the product concerned.

EMH products must be maintained and repaired only by trained, qualified, and authorized personnel.

1.4 Other Notes

Products will only continue to perform reliably, consistently and satisfactorily in the long term if operated, maintained, and repaired by persons specifically assigned to these tasks by the company or its agent. Such persons must be familiar with the installation, operation, and maintenance instructions and the applicable safety regulations and accident prevention regulations.

These operating instructions must be available to all of the personnel responsible for the repair and the maintenance work at all times. EMH products are largely maintenance-free. But, no moving equipment is made by any manufacturer that is inspection or maintenance free. The maintenance work that is required is limited, but must be performed in accordance with the operating instructions and the maintenance schedule by trained, qualified and authorized personnel. In addition, the personnel responsible for repair and maintenance work must initial and date the operating instructions and the maintenance schedule.

2. Safety

2.1 General Safety Information

This installation, operation and maintenance manual and the instructions must always be stored near the EMH traveling crane and must be available to operating personnel at all times. The installation, operation and maintenance instructions should be displayed in such a manner as to be protected (such as a laminate), and a printed or electronic copy should be kept in another safe, accessible place.

Operating, maintenance and repair personnel must have read and understood the operating instructions before starting work. Therefore EMH suggests that evidence of repairs or maintenance be available for your company's or agent's use.

The company or agent operating an EMH crane is responsible for supervising personnel to ensure that traveling cranes are properly operated. Details of maintenance should be kept in similar places and manners as the instructions, safely in the event of the destruction or unavailability of this manual.

2.1.1 Requirements

EMH products are manufactured and tested and EMH products must be operated in accordance with the requirements of United States codes, standards and regulations. CMAA is the abbreviation for Crane Manufacturers Association of America. NEC is the abbreviation for National Electric Code. ANSI is the abbreviation for the American National Standards Institute.

The following codes, standards and regulations are applicable and must be observed by the operator. The following list should not be considered all inclusive and does not reflect state or local regulations that may apply:

B30.2- Overhead and Gantry Cranes

B30.10- Hooks

B30.11- Monorails and Underhung Cranes

B30.17- Overhead and Gantry Cranes

CMAA Consensus of National Electric Code

CMAA Specification 70- Specification for Top Running Bridge and Gantry type Multiple Girder Electric Overhead Traveling cranes

CMAA Specification 74- Specifications for Top Running and Under Running Single Girder Electric Overhead Cranes Utilizing Under Running Trolley

CMAA Specification 78- Standards and Guidelines for Professional Services Performed on Overhead and Traveling Cranes and Associated Hoisting Equipment.

2.2 Safety Instructions for the User

Caution! For safe working, it is absolutely essential for operation and maintenance personnel to receive thorough instruction in the requirements of the EMH Installation, Operation and Maintenance Manual. A receipt signed by all persons operating and maintaining the equipment shall be kept securely in a safe place. This receipt shall be considered as evidence of manual compliance. There is no substitute for complete documentation.

Release all locking devices before starting the crane.

Switch off the mainline disconnect switch in hazardous situations.

At the end of the work day, place the load suspension devices, such as grab or magnet, on the ground. Pull up the empty hook, and home the crane. For service, the mainline disconnect must be in the off position. Apply lockout and tagout procedures per OSHA regulations. In all events, be guided by United States Occupational Safety and Health Administration (OSHA) regulations as they may be changed or amended after the publication of this manual. Those regulations are superior to and exceed anything mentioned in this manual, to the contrary.

All accident prevention regulations and regulations issued by federal, state, or local authorities, and the operating instructions for cranes indicated on any respective information or name plate, must be adhered to when operating or attending to the crane. The instruction plate must be affixed in a position where it is clearly visible to the crane operator at any time per ANSI B30.2.

Some of this information consists of excerpts from the "Crane Operators Manual" prepared and published by the Crane Manufacturer's Association of America. Be advised that said manual may change after the time of the printing of this document. Accordingly, follow any changes, deletions, or amendments to the same. The term "crane," which will be used in the text below, also stands for trolleys running on rails. "Crane Operator" is the person operating the crane whereas "crane attendant" means the person responsible for the maintenance of the crane or the trolley.

If the company or its agent must abide by existing local regulations for crane operation, the following notes shall remain valid as long as they do not expressly conflict with these local regulations. It is not intended that the following take precedence over existing plant safety rules and regulations, OSHA regulations, or instructions issued by the Crane Manufacturer.

1. Before the initial start-up of a crane or before re-operation after a major modification has been done, cranes must be inspected by an expert commissioned by the operating establishment.
2. Cranes must be inspected by an expert commissioned by the operating establishment at least once a year and if need be, more frequently, depending on their operating conditions and the conditions within the factory. (See Section 5.3.3" Scheduled Inspections")
3. The results of such inspections must be recorded in writing and kept on a file kept in a safe place, fixed in any tangible medium of expression now known or hereafter devised, which can be perceived by the senses and reproduced.
4. The following groups of persons may be employed as crane operators or crane attendants:
 - Persons who have completed their 18th year of age; and,
 - Persons who are physically and mentally suited to those activities, with or without legal accommodation; and,
 - Persons who have been instructed in the operation and maintenance of a crane and who were able to furnish proof of their qualifications to the company, which qualifications were in fact verified by the company; and,
 - Persons who are expected to reliably fulfill the tasks assigned to them and,
 - These persons are required to have been appointed crane operators or attendants by the company.
5. It would be prudent to devise a check list and have it in readiness before starting daily work. The crane operator must check on the performance of the brakes and emergency stop devices and see whether he can detect any defect on the crane. The crane operator must proceed with great care regardless of the existence of safety devices. These devices are to provide the necessary safety in the event of an operator mistake.
6. The crane operator must stop crane operation immediately as soon as it is safe to do so, when any defect jeopardizing operational safety becomes apparent.
7. The crane operator must notify the responsible supervisor at the time of detection and also at the end of his shift, and advise the relief operator of any defect detected on or about the crane.
8. Controlling equipment must only be operated from operating stands or locations.
9. The crane operator must make sure that:
 - Before activating the power supply to the drive units, all control units are in switch-off position.
 - Before leaving the operating stand, all controlling units have been returned to switch-off position and the power supply has been shut off or disconnected.

10. In the event of a storm or when finishing work, the crane operator must make sure that cranes exposed to wind are properly secured by means of locking devices.
11. If the crane operator cannot observe the load in all crane movements or, if in the case of no-load operation, the operator cannot keep an eye on the load suspension device, he may only operate the crane by following the instructions of a second person. This does not apply to program-controlled cranes.
12. The crane operator must give pre-arranged warning signals. These signals must be generally known in the working area and previously devised.
13. The load must not be lifted over people or areas that people are occupying.
14. To move a manually slung load, the crane operator must wait until the correct corresponding signal has been given by the signaller, or a guard posted on or near the crane. This must be a competent and qualified person, who has been appointed by the company or its agent. Insofar as the communication with the crane operator requires the use of signals, the signals must have been previously agreed upon between the crane operator and such competent person.
15. As long as the load is suspended from the hook, the crane operator must keep the control unit (pendant or radio control) within easy reach. It must be kept in mind at all working times, that the control must be in near proximity to the operator in the event of an emergency.
16. Regular crane operations approaching the final position, which is limited by an emergency stop device, are only permissible if an additional stopping device is series-connected. With program-controlled cranes, all working and traffic areas must be safeguarded in such a way that the crane in motion or any falling objects will not cause damage to persons or property.
17. Crane loads may not exceed the permissible maximum weight capacity of the crane or hoist. The capacity is prominently displayed on each hoist and on the crane girder.
18. The operator must be sure that when placing objects to be lifted near the crane, there is a safe distance of at least 2 feet, that is, between the external movable parts of the crane and these objects to be lifted.
19. (1) In the event of an overlapping of the work-ranges of several cranes, that is, cranes that could come in contact with each other, the company and its agent must previously arrange a work schedule. The objective is to create all the conditions for a trouble-free communication between the crane operators.

(2) Before a load is simultaneously handled by more than one hoist or crane, the company or its agent must have arranged an appropriate work schedule. This work schedule must be carried out under the supervision of a trained, qualified and authorized person appointed by the company or its agent.
20. There can be a great danger when maintenance is done on a crane or hoist. Maintenance work must only be done after the crane has been switched off or disconnected, whichever is secure and safe. Any maintenance work that cannot be carried out from the ground must be carefully done from secure working stands or platforms. When carrying out maintenance or repair work on the crane, the crane must be unloaded and the mainline disconnect must be switched off and protected from unauthorized switching (locked out). Each switch should be provided with several padlocks. This enables each person working on the crane, by means of his own padlock, to lock and secure the crane against unauthorized switching-on. (See OSHA Regulation 1910.147 Lockout Tagout.) Current OSHA Regulations prevail when there are any inconsistencies, anywhere in this manual.
21. (1) For repair and maintenance work on cranes and in the crane traveling area, the company or its agent must initiate, coordinate and supervise the following safety measures:
 - The crane must be switched off and safeguarded against erroneous or unauthorized electrical activation.
 - If there is any risk of falling objects, the risk area beneath the crane must be secured, or closed off or otherwise be made safe by posting guards to the site.
 - Collisions with other cranes must be avoided. Cranes can be safeguarded against collisions with other cranes by means of rail stops, limit switches, or by stationing authorized personnel to closely observe the crane in motion. Not all cranes are ordered and equipped with anti-collision devices.
 - The crane operators of adjoining cranes must be informed of the activity and location of operations. This applies as well to the relief operator in the case of shift change.
(2) Many companies and operations are different. Accordingly, if any safety procedure has not been properly followed, or was insufficient under the circumstances, the company or its agent should devise different or additional procedures consistent with the safe operation and the environment, attendant to the operation or facility.
22. (1) Unauthorized persons are not allowed to walk onto a crane.

(2) Cranes that are being operated by a crane operator shall only be entered or exited with the consent of the crane operator and only when the crane has come to a standstill.
23. As stated previously, no hoist or crane shall carry people, with or without a load. Passengers should not be carried by the crane under any circumstances.
24. Never wrap the hoisting rope or chain around a load. Do not use the hoisting rope or chain as a sling. Hoisting ropes or chains and the like should never be bent or pulled over sharp edges. Any rubbing of the hoisting rope with other surfaces creates wear and can damage ropes or chains.
25. Never drag or pull the load sideways or use the equipment to move vehicles such as a towmotor or any similar equipment with either the load or the load suspension device. This equipment is not manufactured to be used for any kind of towing.

Caution! The crane must not be used for pulling or separating loads. In other words, do not use the crane for pushing, pulling, or dragging, since this could result in overloading the motor and resulting in downtime and expensive repairs.

26. It is critical that the company or its agent consents to and authorizes the use of any equipment after inspection, maintenance or repair. **This is also true after any work has been done on the equipment, or around the crane traveling area or runway. Crane operation shall only be resumed if the company or its agent has reviewed it and consented to operate the equipment.** It is critical that before the company or its agent has authorized a crane into operation, the company or its agent must be certain that the following has been done:
 - The repair or maintenance work has been completed.
 - The conditions for safe operations of the entire crane are restored.
 - All personnel providing the repair or maintenance have left the crane and traveling area along with their tools and any loose parts in the traveling area.
27. When operating an additional crane or hoist, any special directions from the company or its agent consistent with this manual must be followed unless superseded by regulations or law. If additional equipment is later installed on the crane or the hoist, it is strictly the responsibility of the company or its agent to review the operating of the crane and determine whether any additional equipment is necessary and suited for the crane installation.
28. Be sure that the control devices are operating correctly when starting the crane after work, or if maintenance or repair has been done to the main current supply cables. If there are any wires that are not connected or incorrectly connected, this will interfere with the operation of the crane or hoist and create a danger to people or property.
29. The operator must be certain that the workplace is consistently and adequately lit. Operation of the equipment in poorly lit conditions is not recommended.

Contents	Page
Rail Profiles - - - - -	- 9-10
Rail Capacities and Lengths - - - - -	-- 11
System Dimensions - - - - -	-- 12
Suspensions - - - - -	-- 13
Trolleys - - - - -	-- 14
End Stops - - - - -	-- 15
End Caps - - - - -	-- 15
Crane Girder Suspensions - - - - -	-- 16
Spacers for Double Girder Cranes - - - - -	-- 16
Stooled Up Endtrucks - - - - -	-- 17
Spacer Plates for Telescoping Cranes - - - - -	-- 18
Splices - - - - -	-- 19
Safety Wires- - - - -	-- 19

Rail Profiles

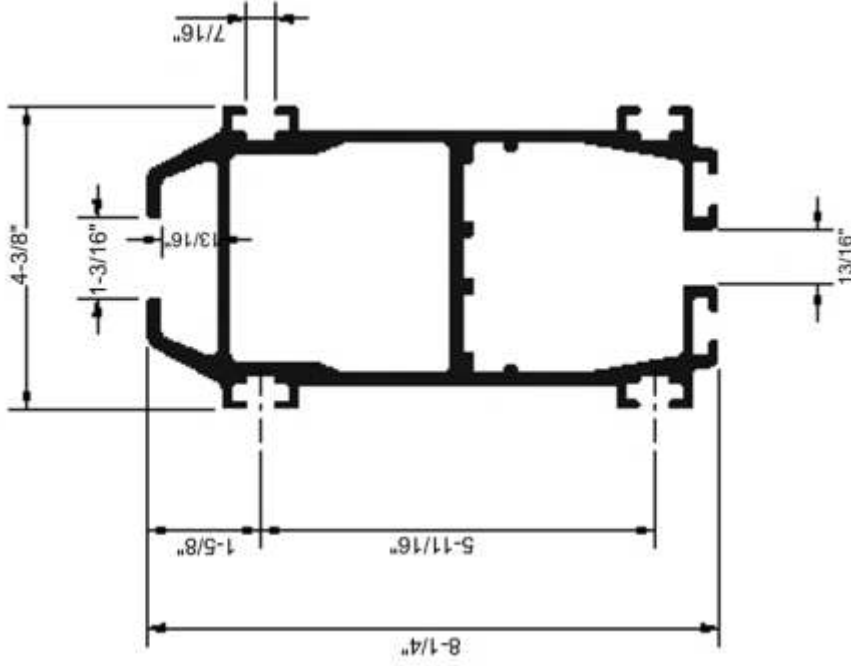
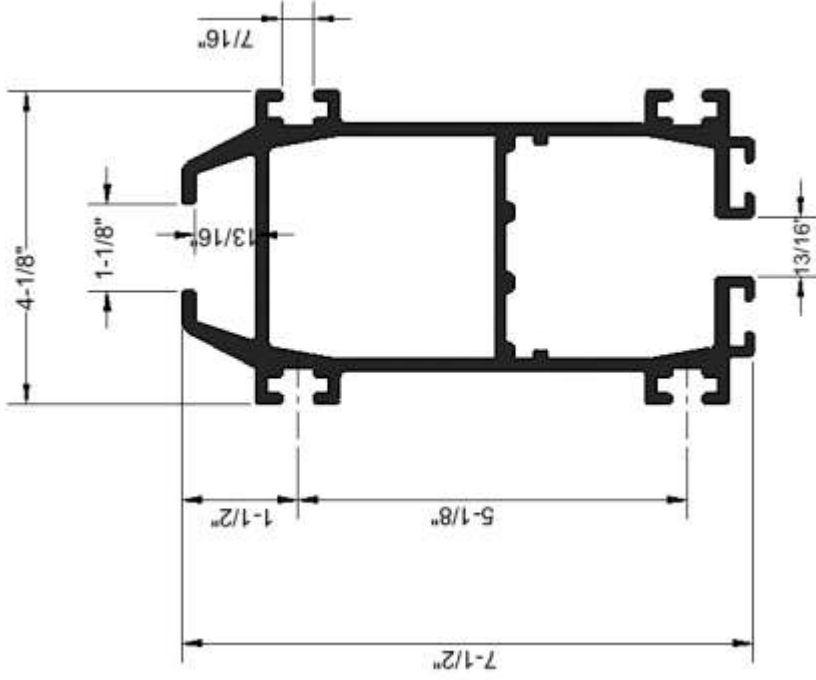
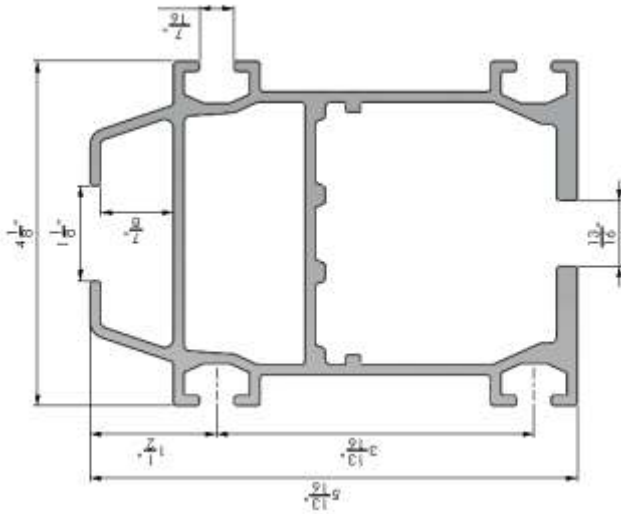

AL 1 Part No.	Length
501003	5
501004	10
501005	15
501006	20
50007	25

AL 2 Part No.	Length
503003	5
503004	10
503005	15
503006	20
503007	25

AL 3 Part No.	Length
504003	5
504004	10
504005	15
504006	20
504007	25

Rail Profiles

INFORMATION

The load tables are calculated for a maximum permissible deflection of 1:250. Max load means the total load including dynamic stresses that may be applied to the trolleys.

1. Use double trolley for AL 2 at loads between 250-500 kg. (550 to 1100 lbs.)
2. Use double trolley for AL 3 at loads between 500-1000 kg. (1100 to 2200 lbs.) Strengthened AL 3 for longer spans can be supplied on request, please contact EMH, Inc.



Rail Capacities & Lengths



Monorail

Max. Load		AL1		AL2		AL3	
		Max LB		Max LB		Max LB	
Lbs.	Kg.	ft.-in.	mm.	ft.-in.	mm.	ft.-in.	mm.
150	68	24-0	7310	---	---	---	---
175	79	23-6	7160	---	---	---	---
200	91	21-6	6550	---	---	---	---
250	113	20-0	6100	---	---	---	---
275	125	---	---	30-0	9140	---	---
300	136	19-6	5940	---	---	---	---
350	160	---	---	27-9	8460	---	---
400	181	17-0	5180	---	---	---	---
440	200	---	---	25-6	7770	---	---
450	204	16-6	5030	---	---	---	---
500	227	15-6	4720	---	---	---	---
550	250	---	---	23-3	7090	27-9	8450
600	272	14-6	4420	---	---	---	---
700	320	---	---	21-3	6470	25-3	7700
750	340	13-0	3960	---	---	---	---
900	408	12-0	3660	19-0	5790	22-0	6700
1100	500	---	---	17-3	5250	21-0	6400
1400	630	---	---	---	---	18-9	5710
1750	800	---	---	---	---	---	---
2200	1000	---	---	---	---	---	---

Rail Capacities & Lengths for Single and Double Girder Cranes shown on Page 12.

Rail Capacities & Lengths



Single Girder

Max. Load		AL1		AL2						AL3			
		Max LB		Max LS		Max LB				Max LS		Max LB	
						AL2		AL3		AL2		AL3	
Lbs.	Kg.	ft.-in.	mm.	ft.-in.	mm.	ft.-in.	mm.	ft.-in.	mm.	ft.-in.	mm.	ft.-in.	mm.
150	68	24-0	7310	---	---	---	---	---	---	---	---	---	---
175	79	23-6	7160	---	---	---	---	---	---	---	---	---	---
200	91	21-6	6550	---	---	---	---	---	---	---	---	---	---
220	100	20-0	6100	25-6	7800	25-6	7800	---	---	---	---	---	---
250	113	---	---	---	---	---	---	---	---	---	---	---	---
275	125	19-6	5940	25-6	7800	25	7700	---	---	---	---	---	---
300	136	---	---	---	---	---	---	---	---	---	---	---	---
350	160	17-0	5180	25	7600	23-6	7200	---	---	---	---	---	---
400	181	---	---	---	---	---	---	---	---	---	---	---	---
440	200	16-6	5030	23	7000	22	6700	---	---	25-6	7800	25-6	7800
500	227	15-6	4720	---	---	---	---	---	---	---	---	---	---
550	250	---	---	21-6	6600	20-6	6300	25-6	7800	25-6	7800	25	7600
600	272	14-6	4420	---	---	---	---	---	---	---	---	---	---
700	320	---	---	19-6	6000	19-6	6000	24	7300	24-6	7500	23	7100
750	340	13-0	3960	---	---	---	---	---	---	---	---	---	---
900	400	12-0	3660	18	5500	18	5500	22	6700	22-6	6900	21-6	6600
1100	500	---	---	16	4900	17	5200	20-6	6300	21	6400	20	6100
1400	630	---	---	---	---	---	---	---	---	18-6	5600	17-6	5400
1750	800	---	---	---	---	---	---	---	---	16-6	5100	16	4900
2200	1000	---	---	---	---	---	---	---	---	15	4600	15	4500

Double Girder

Max. Load		AL2						AL3			
		Max LS		Max LB				Max LS		Max LB	
				AL2		AL3		AL3		AL3	
Lbs.	Kg.	ft.-in.	mm.	ft.-in.	mm.	ft.-in.	mm.	ft.-in.	mm.	ft.-in.	mm.
350	160	25-6	7800	21-6	6600	---	---	---	---	---	---
440	200	25-6	7800	20	6200	25-6	7800	---	---	---	---
550	250	25-6	7800	19	5800	24	7400	25-6	7800	23	7000
700	320	24-6	7500	17	5300	22	6800	25-6	7800	21	6500
900	400	23-6	7200	16-6	5100	21-6	6600	25-6	7800	20-6	6300
1100	500	21-6	6600	15-6	4700	19-6	6000	25-6	7800	19	5800
1400	630	20	6100	14	4300	18	5500	24	7400	17-6	5300
1750	800	18	5500	13	4000	16	4900	22-6	6900	15-6	4800
2200	1000	16	4900	11-6	3500	15	4600	21	6400	14-6	4400

Rail Capacities & Lengths for Monorails shown on Page 11.

System Dimensions

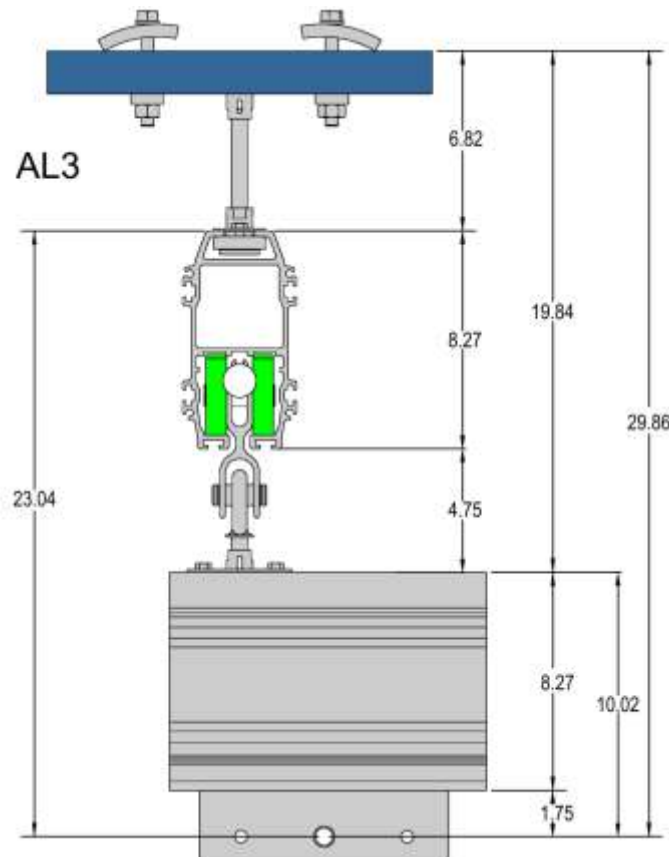
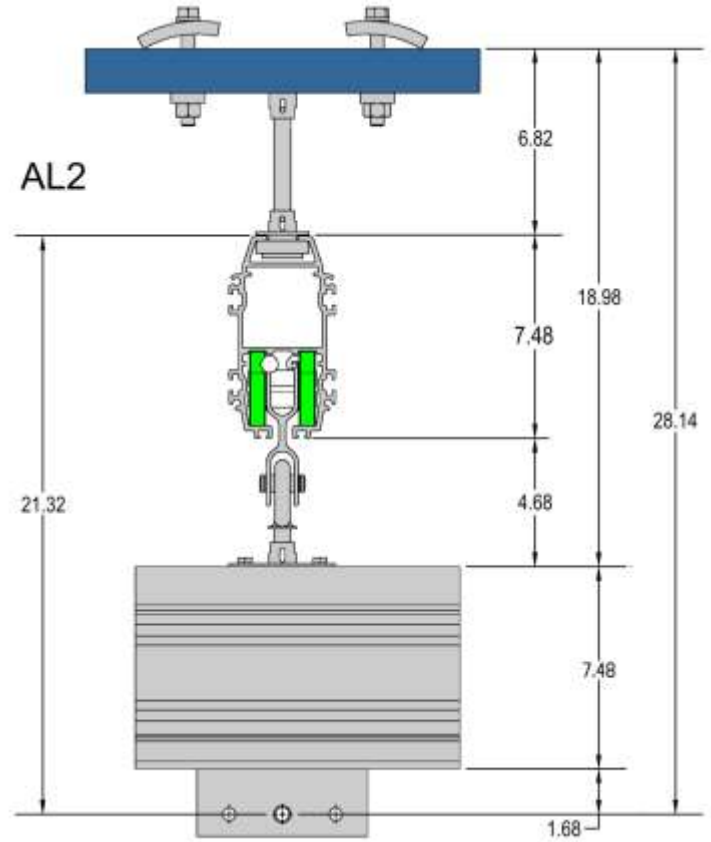
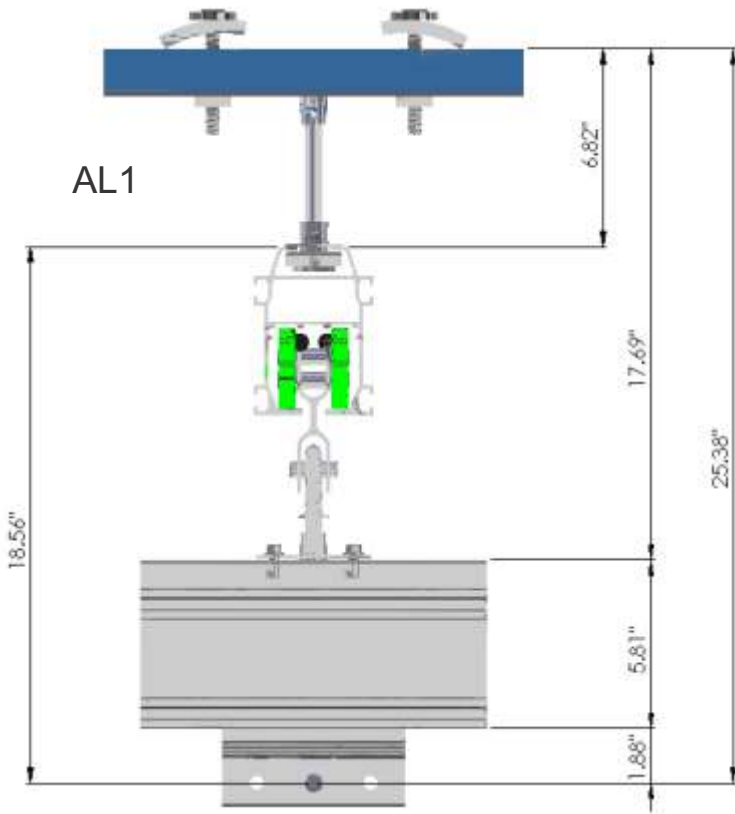

Suspensions



Type A



Type B

AL 1,2&3 Part No.	Type	FB (in.)	FT (in.)	Weight (kg.)
504025	A	4-10	1/2	3.9 ea.
	B	4-10	1/2	
	C (L)	4-10	1/2	
	C (T)	4-10	1/2	

50351 | B with Sway Brace

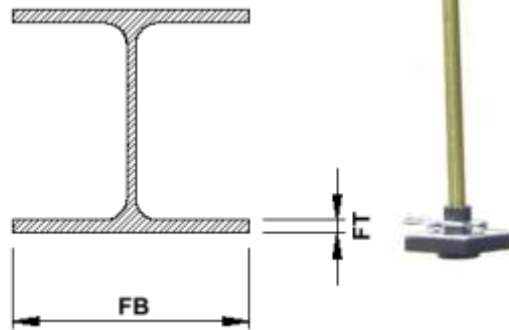

Type C

Type B with Sway Brace



Trolleys

AL1&2 Part No.	Type	Max Load kg	Weight kg	Force of Impact Max (N)
502008	Single	250	1.2	200
502026	Double	500	<14	200

AL3 Part No.	Type	Max Load kg	Weight kg	Force of Impact Max (N)
504026	Single	500	2.8	300
504027	Double	1000	9.8	300

Type A

AL2
502008



AL3
504026



Type B

AL2
502026



AL3
504027



AL2
5030058

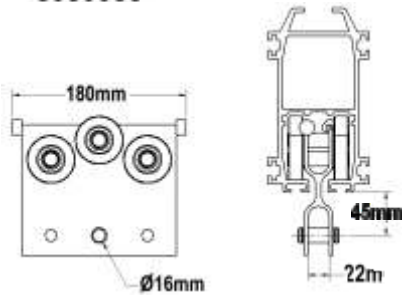

AL3
504026

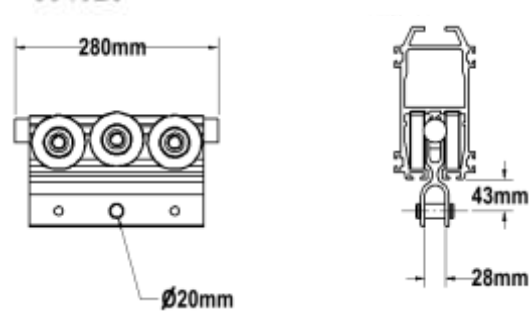

AL2
503026

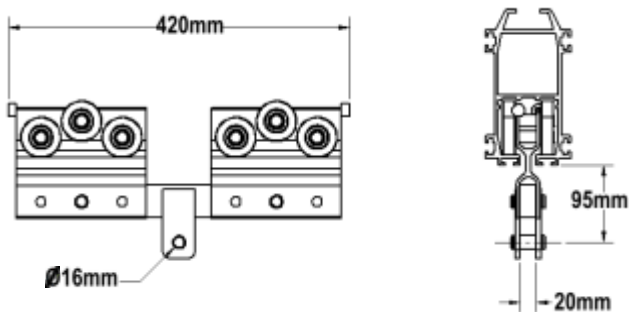

AL3
504027

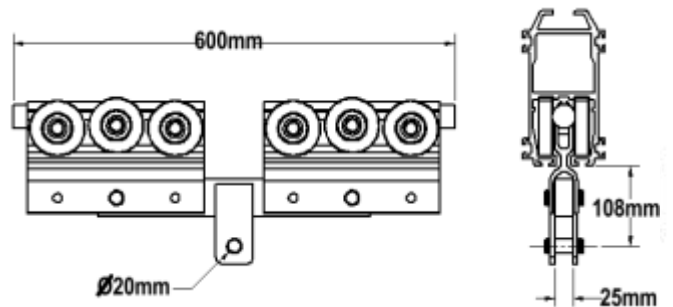

End Stops



Rail Type	Part No.	Type (see box)	Weight kg
AL2	503010	Standard	0.6
AL2	503640	Auxiliary	0.7
AL3	504010	Standard	0.7
AL3	504641	Auxiliary	0.7

*
 Standard Type: Mounted from above
 Special Type: Mounted from below (on profile end in compact mounting, remember that the nut can be reached only from the end).
 NOTE: Drilled-through end stops must always be mounted in track and crane!
WARNING: A drilled end stop is required at all track ends.

AL 1
501010

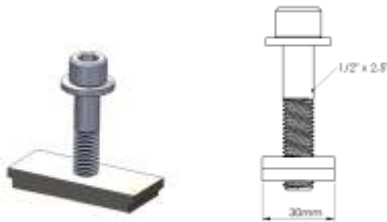

Standard
AL 2
503010



AL 3
504010

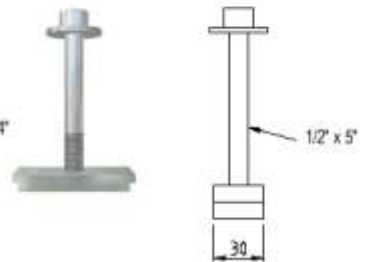

Auxiliary

AL 2
503640

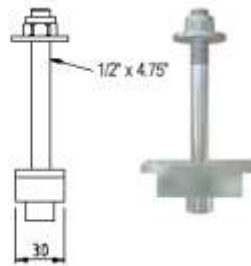

AL 3
504641



End Caps

AL1 Part No.	Weight kg
501008	0.3

AL 1
501008

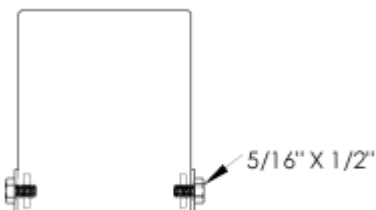

AL2 Part No.	Weight kg
503008	0.6

AL 2
503008

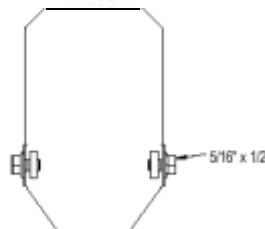

AL3 Part No.	Weight kg
504008	0.7

AL 3
504008

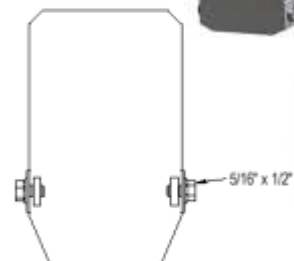

Crane Girder Suspensions



AL3 Part No.	Max load lbs.	Weight lbs.
504023	2700	3

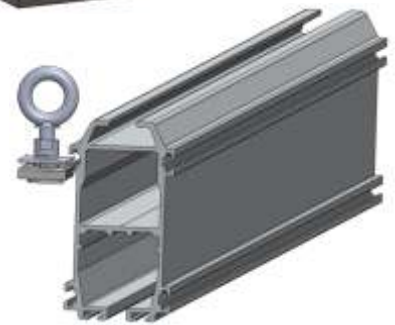
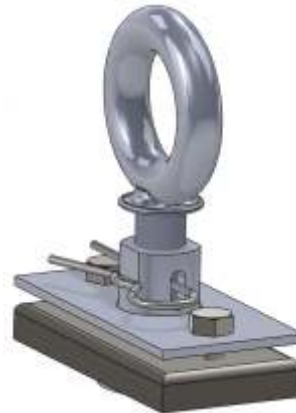
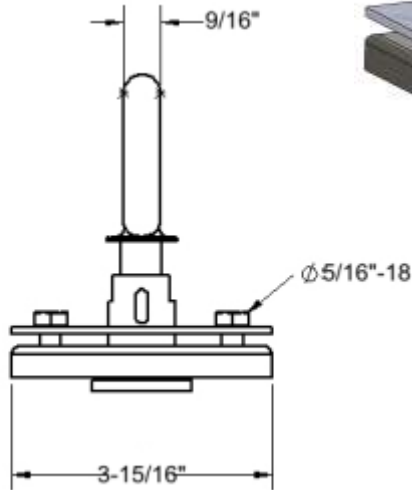
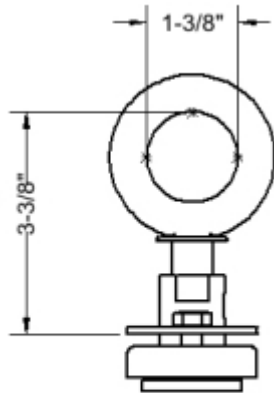

Spacers for Double Girder Cranes

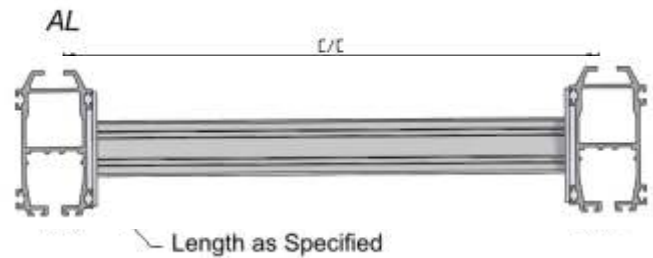

INFORMATION:

Used in pairs between the profiles in the crane. NOTE: Sold in pairs.

C/C=Center-to-center dimension between the profiles in the crane.

Stooled-Up Endtrucks



AL2 Part No.	Type	Length Crane (cc)	Weight kg/pr	C/C Crane (mm)
503404	Single	250-3000	18	---
503406	Single	>3000<6000	20	---
503407	Single	>6000<8000	22	---
503405	Double	250-8000	26	800
503357	Double	250-8000	29	100

AL3 Part No.	Type	Length Crane (cc)	Weight kg/pr	C/C Crane (mm)
504457	Single	250-3000	28	---
504459	Single	>3000<6000	30	---
504460	Single	>6000<8000	34	---
504570	Double	250-8000	36	800
504458	Double	250-8000	40	100

AL 2



AL 3



AL 2



AL 3



INFORMATION:

Used when lift height is a critical factor. SOLD IN PAIRS.

Variations on request, contact EMH, Inc. For information

Single

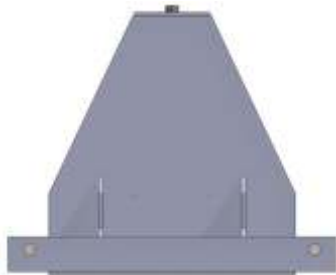

503406



503407

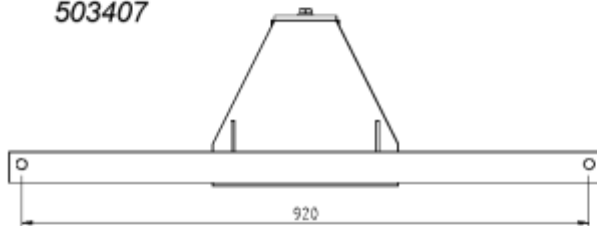

AL 3
504457

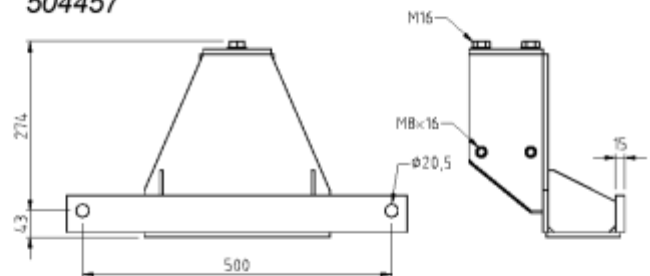

504459

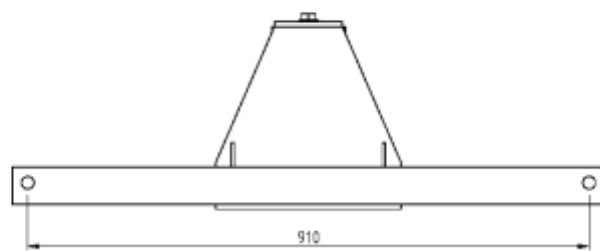
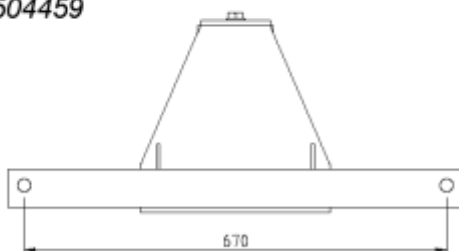

Spacers for Telescoping Cranes



AL2 Part No.	Weight kg
503349	0.5

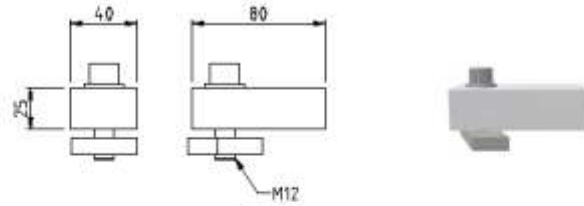

AL3 Part No.	Weight kg
504460	0.5

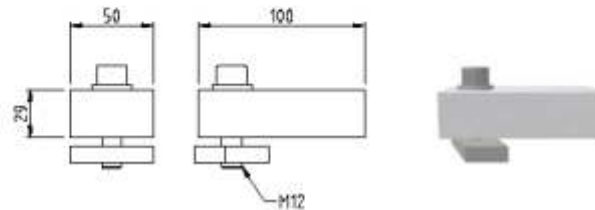

Splices



AL1	Weight
Part No.	kg
506009	2.3

AL2	Weight
Part No.	kg
503009	2.5

AL3	Weight
Part No.	kg
504009	2.6

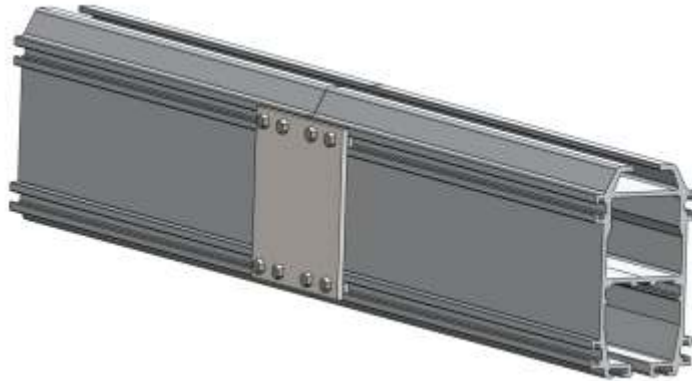

Safety Wires

AL 2-3	Type	Max Load N	Diam. mm
503026	A	5000	165



IMPORTANT:

Safety wires are required at every crane suspension.

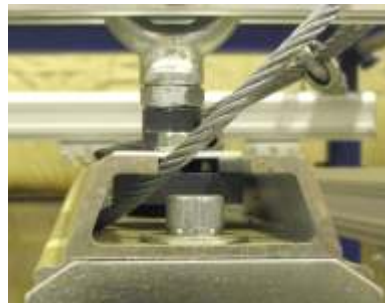

TORQUE SPECIFICATIONS FOR CROSBY CLIPS (circled on upper left photo):

1/4" cable: 15 ft-lbs

MUST BE HAND TORQUED. NO ELECTRIC OR PNEUMATIC IMPACT WRENCHES.

Cranes \leq 1000 lbs. use one cable per crane suspension.

Cranes \geq 1000 lbs. use two cables per crane suspension.

Contents	Page
End Fix - - - - -	-- 22
Cable Towing Arms - - - - -	-- 22
Cable Trolleys- - - - -	-- 23
Cable & Hose Clamps - - - - -	-- 24
Wire Brackets- - - - -	-- 24

End Fix



AL Part No.	Type	Max load kg	Weight kg
501012	A	10	0.2
501014	B	10	0.15
501016	C	10	0.2

Type A

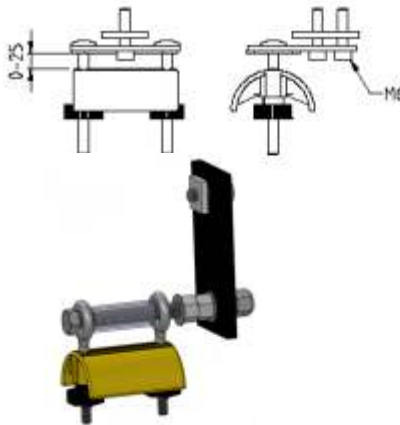

Type B

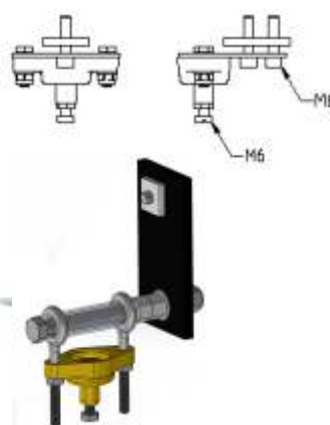

Type C

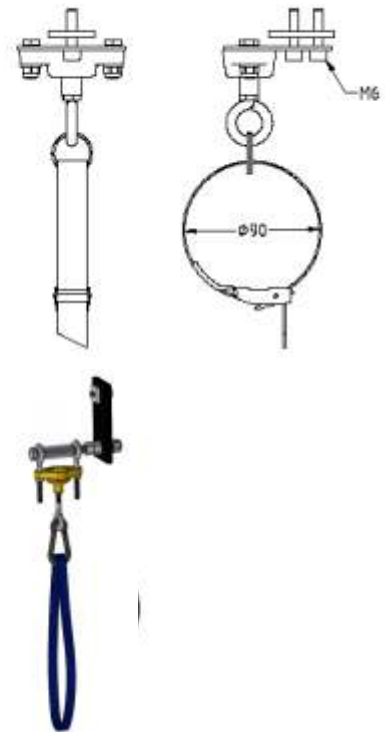

Cable Towing Arms

AL Part No.	Type	Max load kg	Weight kg
501013	A	10	0.2
501015	B	10	0.15
501017	C	10	0.2

INFORMATION

Type A = Saddle
 Type B = Ball joint, complete with cable/hose clamp type A, section *Cable & Hose Clamps*
 Type C = Strap

Type A

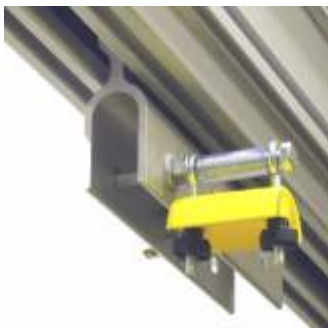

Type B



Type C



Cable Trolleys



Type A

AL

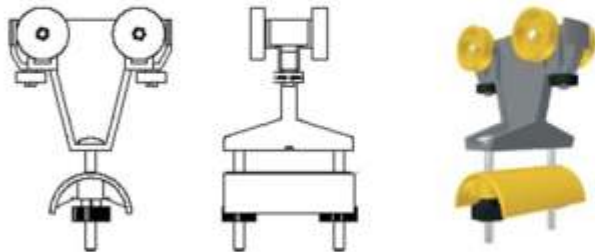

Type B

AL

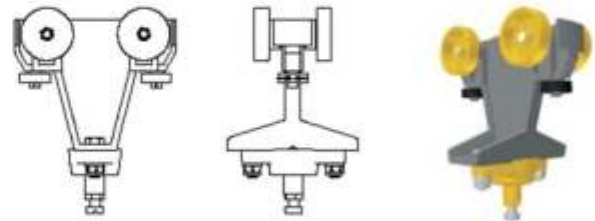

Type C

AL

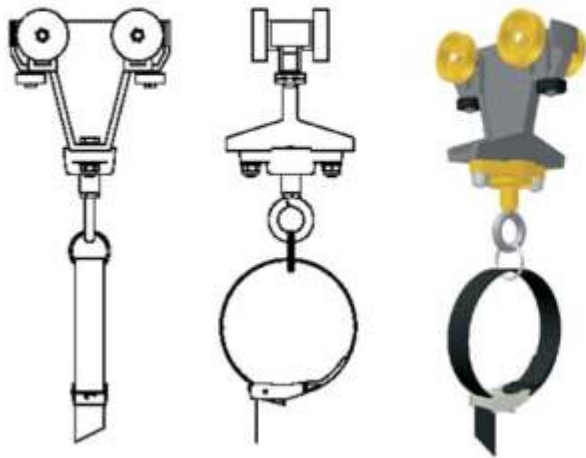

Type D

AL



AL Part No.	Type	Max load kg	Weight kg
503027	A	10	0.15
503028	B	10	0.15
503030	C	10	0.15
4537	D	10	0.1

Cable & Hose Clamps



Part No.		kg	kg	mm
503473	A	10	0.05	10-16
503474	A	10	0.06	17-25
403475	A	10	0.1	26-36

Type A



503473



503474



503475

Wire Brackets

AL Part No.	Weight kg/pair
503053	0.5



INFORMATION:

NOTE: Sold in pairs, with wire and crosby clips (4). Wire is ordered separately. Avoid suspension distance greater than 15 meters.

Accessories

Contents	Page
Cable Fitting & Hose Couplings - - - - -	-- 25
Fasteners - - - - -	-- 25

Cable & Hose



Cable - Round	
Part No.	Type
6753	7 conductor, 14AWG

Cable - Flat	
Part No.	Type
6761	4 conductor, 14AWG



Hose - Coiled		
Part No.	Diam. X Length	Info.
AH85A25	3/8" diam x 25'	PUR
AH85A50	3/8" diam x 50'	PUR
AH85A100	3/8" diam x 100'	PUR
Hose length equals 1.25 x runway length		

Fasteners



T-nut

Fasteners		
Part No.	Type	Size (in.)
500001	T-Nut	
BS5161812	Screw	5/16" x 1/2"
BS5161858	Screw	5/16" x 5/8"
BS5161834	Screw	5/16" x 3/4"
6139	Diamond Nut	



Screw



Diamond Nut



<u>Contents</u>	<u>Page</u>
Installation.....	27-31
Maintenance.....	31
Inspection Protocol.....	32

Installation



Tolerance requirements

Horizontal plan - Overhead structure

Overhead structure may not exceed the tolerance of ± 10 mm horizontally.

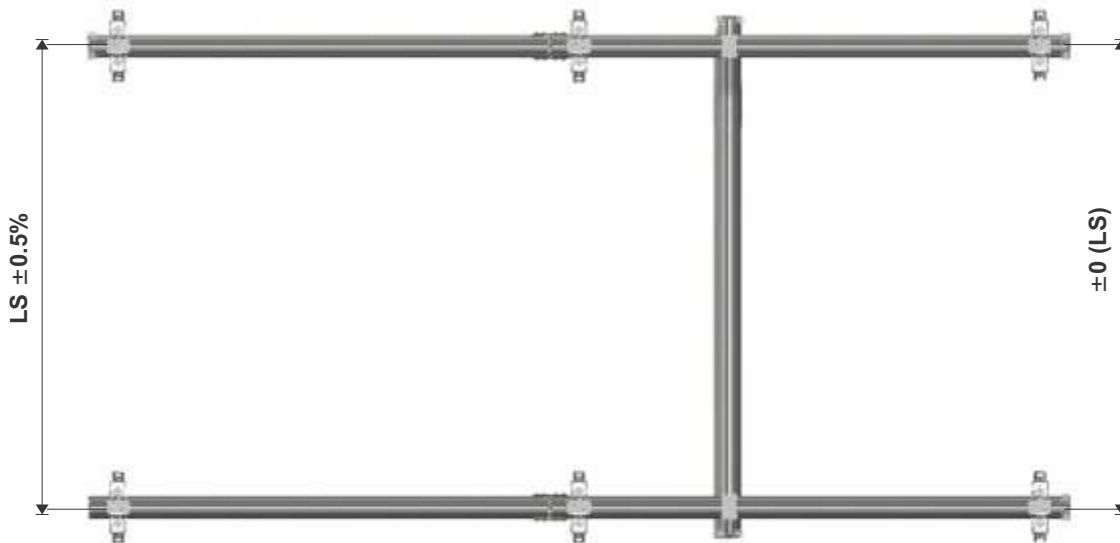
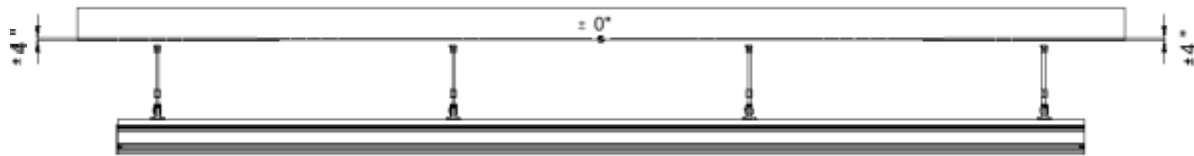

Tips & advice

Due to the great number of possible combinations within the AL Systems product line, only general tips and advice are found here.

Carefully plan what to install as well as the installation sequence before beginning work.

When possible, install components on the ground before putting up the system. For instance, the drilled holes necessary for end stops are virtually impossible to drill out once the rail is suspended, so make these holes while on the floor. It is best to clean the running track before inserting trolleys.

Installation



1. Unpack material, identify and inventory all parts. Review installation drawing if provided.

2. Lay Out System

a. If free standing or lamppost, determine all column locations. Drill and install anchors., level, and plumb before proceeding.

b. If ceiling mounted, determine all suspension locations.

3. Install runway suspensions, tighten flange clamps (if rigid mounted, install on runway beams before installation)

4. Install suspension rods and safety pins if applicable.



a. If sway brace brackets are required, please see drawing at right..

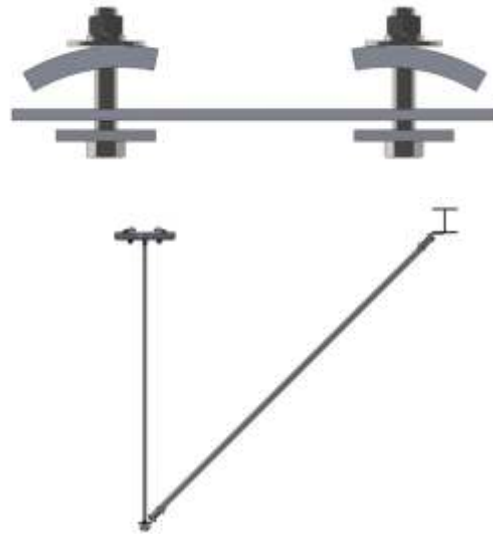

5. Install drilled endstop on all rail ends, runway and bridge (we highly recommend you do this on the floor). End stops should be drilled in the center of the rail and plum.

a. If using sliders, festoon trolleys, etc. inside the rail, place end stop in front of the festoon components in the rail at the stack up end. At rail ends other than "stack up" ends, end stop can be placed 1.5" from end of rail.

Drill Here for End Stops



6. Install runway suspension brackets in top of runway.

Installation



7. Lift runway rail into place, thread suspension rods into ball nuts and install safety pins through ball nuts and rods at both ends.



a. If runway requires more than one piece of runway rail, install splices in "T" slots on sides and bottom of rail. Bring the rail sections together so that half of splice plates are on each piece of rail and tighten in cross pattern according to diagram.

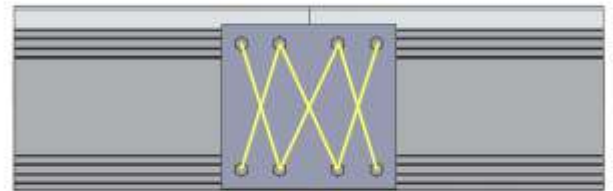

8. Install end truck trolleys in the rail. NOTE: You will need to remove drilled end stop first.

a. Depending on capacity of system, trolleys may be single or double trolley with load bar.

9. Install festoon (sliders, trolleys, etc.)

10. Install end caps.

11. Assemble bridge crane on floor.

a. Place crane girder suspension in top of rail according to the required span.

b. If stooled up crane, install low headroom end truck modules in lieu of crane girder suspensions.

c. If double girder, install crane distance profiles a minimum of 1" from end of rail.

d. Depending on capacity of system, trolleys may be single or double trolley with load bar.

e. Install load trolley. Depending on capacity of system, trolleys may be single or double trolley with load bar.

f. Install festoon (sliders, trolleys, etc.)



Installation



g. Install end caps.

12. Raise and install crane onto runway.

a. Remove load pins from end truck trolleys.

b. Place crane girder suspension eye so that center of eye is lined up with load pin in trolley.

c. Insert pin and install safety clips.

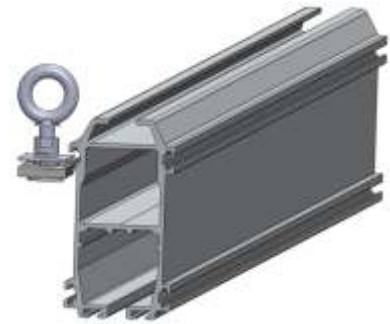

13. Install safety cables at all crane girder suspension locations (if single girder, two; if double girder, four.)

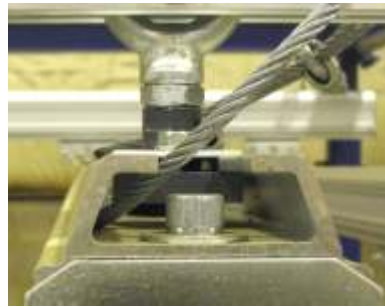

14. If festoon system is tagline and coiled hose, install at this time according to drawing.

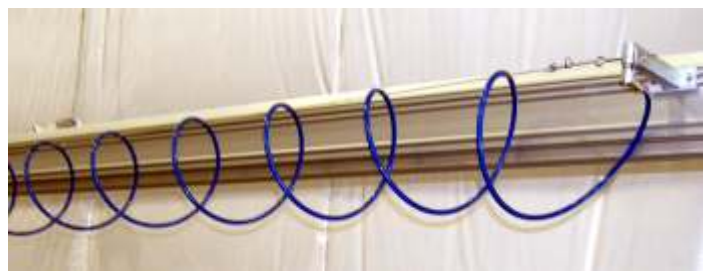

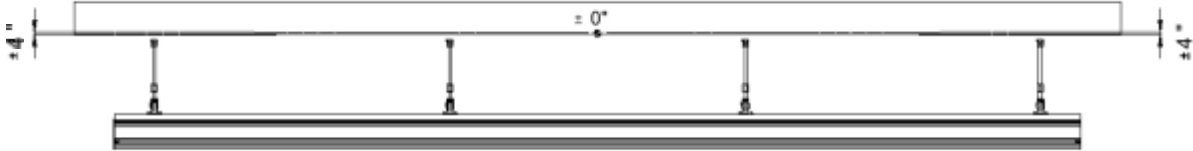

Tolerance requirements

Horizontal plan - Overhead structure

Overhead structure may not exceed the tolerance of ± 10 mm horizontally

Straightness - Tracks

The suspensions for a track may not be placed with a greater deviation than + or - 0.5% from parallel.

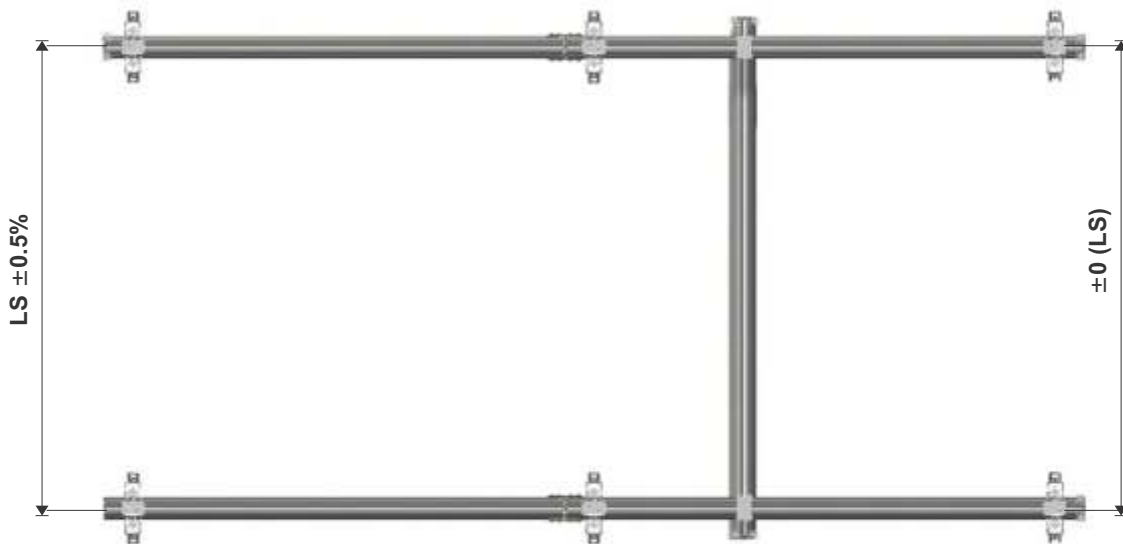

Inspection Protocol



AL Systems Rail						
To:		Client/ place:		Installed per instructions	Not applicable	The installation protocol shall be kept by the client/user.
Service by:		Date:				
Types of Inspection indicated for each component: Visual (V): Examine for visible signs of damage or deterioration. Auditory (A): Listen for suspicious sounds such as grinding. Physical (P): Feel or manipulate to detect damage or deterioration. Mechanical (M): Examine for damage or deterioration with tools.						
#	Product	Checked			Inspecting Dept./Signed	Comment
2.1	Rail profiles	V, P Clean running surface in the profile where the trolley moves. The surface shall be clean and dry. Dirty and greasy running surfaces will inevitably affect performance. Use a clean and dry cloth.				
2.2	Suspensions	V, P, M				
2.3	Trolleys	V, A, P, M Check that the trolley runs quietly and without difficulty along the entire section				
2.4	End stops	V, P, M				
2.5	End caps	V, M				
2.6	Crane girder suspensions	V, P, M				
2.7	Spacers for double cranes	V, P, M				
2.8	Design modules for double cranes	V, P, M				
2.9	Spacer plate for telescoping cranes	V, P, M				
2.10	Joint sets	V, A, P, M Make sure that the runway is flat over the splice test with trolley.				
2.11	Travel limits	V, A, P, M Limit switches with hydraulic dampers are also checked with regard to leakage.				
2.12	Safety wires	V, A, P, M Check that the safety wires are unloaded.				
2.13	Parking brakes	V, A, P, M				
2.14	Limit switches	V, P, M Check that the intended function is obtained.				
2.15	Grounding cables	V, P, M				
3.1	Air preparation units	V, A, P, M See product information.				
3.2	End fix	V, P, M Check whether cables or hoses are damaged.				
3.3	Cable towing arms	V, P, M Check whether cables or hoses are damaged.				
3.4	Cable trolleys	V, A, P, M Check that the trolleys run quietly and without difficulty along the entire section.				
3.5	Cable & hose clamps	V, P, M Check whether cables or hoses are damaged.				
3.6	Wire brackets	V, P, M				
3.7	Coupling units	V, P, M Check whether cables are damaged.				
3.8	Cable & hose	V, A, P, M				
3.9	Media profile	V, P, M				

Inspection Protocol



3.10	Cover	V,A,P,M				
3.11	Beam suspensions	V,A,P,M				
3.12	Profile suspensions	V,A,P,M				
3.13	Joint sets	V,A,P,M				
3.14	Cable towing arms	V,A,P,M				
3.15	Cable chains	V,A,P,M Check whether cables or hoses are damaged.				
3.16	End fix	V,P,M				
3.17	Cable & hose inlet	V,A,P,M				
3.18	Supporting blocks	V,P,M				
3.19	Cable trays & brackets	V,P,M				